

Venturi Loaders

VL series venturi loaders use fast flowing pressurized air to create a vacuum that is used to convey various plastic granules. Air pressure is around 5 - 6 kgf / cm².



VL-50



VL-100

Features

- Euro style, compact in size and light - weighted.
- Stainless steel made material hopper and base ensure no contamination of materials.
- Filtered exhaust air does not pollute environment.
- Silent operation, it uses high - pressure air to convey materials.
- Capacitive sensor mounted onto the glass - tube for accurate level sensing.
- Compressed air filter and regulator to eliminate moisture and maintain steady air pressure.
- Quick installation and easy operation with surface polished.
- Easy access to material hopper for convenient cleaning.
- Hopper mount position adjustable.

Structural View

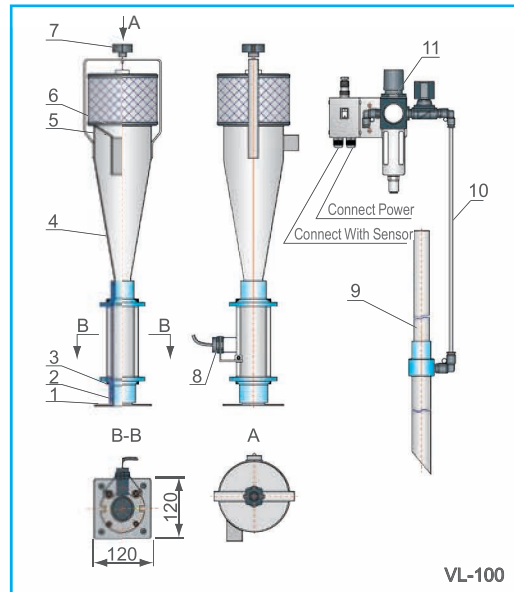
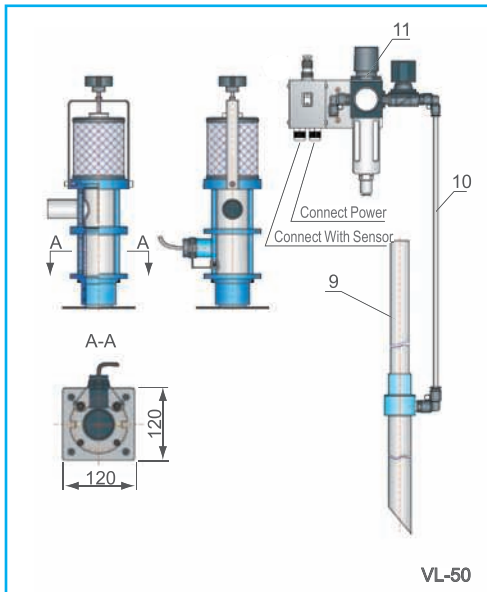

1. Base
2. O-ring
3. Flange connecting pole
4. Hopper
5. Material flap
6. Air filter
7. Fixing knob
8. Sensor
9. Conveying pipe
10. Air pipe
11. Compressed-air filter, lubricator cap & regulator

Applications

Venturi loaders use fast flowing pressurized air to create a vacuum that is used to convey various plastic granules. Air pressure is around 5 - 6 kgf / cm².



Specifications

| Model | Conveying Capacity (kg / hr) | Material Hopper (L) | Max. Conveying Distance (m) | Conveying Pipe (inch) | Length of Suction Pipe (mm) | Dimensions (mm) (H × W × D) | Weight (kg) |
|--------|------------------------------|---------------------|-----------------------------|-----------------------|-----------------------------|-----------------------------|-------------|
| VL-50 | 30 | 0.5 | 6 | 1.25" | 900 | 380 × 145 × 150 | 4.5 |
| VL-100 | 180 | 2.8 | 6 | 1.25" | 900 | 720 × 165 × 160 | 7 |

Note: 1) For hopper inside polished ones, plus " P " at model behind.
 2) Note: Power supply 1Φ, 115 / 230V, 50 / 60Hz.

We reserve the right to change specifications without prior notice.

SHINI PLASTICS TECHNOLOGIES, INC.

Corporate Strategic Center

Overseas Business Department:
 Dalang, Dongguan, Guangdong, China
 Tel: (0769) 8111 6600
 Fax: (0769) 8111 6611
 Email: shini@shini.com