

SCM

Volumetric Doser

Date: Apr. 2019

Version: Ver.G (English)



Contents

1. General Description	7
1.1 Coding Principle	8
1.2 Features	8
1.3 Accessory option	9
1.4 Machine Specifications	10
1.4.1 Dimensions of Doser	10
1.4.2 Specification List	11
1.5 Safety Regulations	13
1.5.1 Safety Signs and Labels	13
1.6 Exemption Clause	14
2. Structure Characteristics and Working Principle	15
2.1 Working Principle	15
2.2 Assembly Drawing and Parts List	16
2.2.1 Assembly Drawing of Single-color Doser	16
2.2.2 Parts List of Single-color Doser	17
2.2.3 Assembly Drawing of Double Color Doser	18
2.2.4 Parts List of Double Color Doser	19
2.2.5 Assembly Drawing of High Temp. Doser	20
2.2.6 Parts List of High Temp. Doser	21
2.3 Electrical Circuit Descriptions	22
2.3.1 Electrical Descriptions	22
2.3.2 Electrical Components Layout	25
2.3.3 Electrical Components List	26
2.4 Optional Accessories	27
2.4.1 Main hopper	27
2.4.2 Mixing System	27
2.4.3 Heavy base	28
3. Installation and Debugging	29
3.1 Install on Extrusion or Injection Molding Machine	29
3.2 Power Supply Wiring	30

4. Operation.....	31
4.1 Control Panel (SCM).....	31
4.2 Start/Stop of the Machine.....	31
4.3 Operation Instruction.....	32
4.3.1 IMM Mode Setting.....	32
4.3.2 Extruder Mode	35
4.3.3 Other Function Setting.....	36
4.3.4 Other Parameters Function	37
4.4 Replace Dosing Screws	40
5. Trouble Shooting.....	41
6. Maintenance and Repair	42
6.1 Repair	42
6.2 Maintenance	42
6.3 Maintenance Schedule.....	42
6.3.1 About the Machine.....	42
6.3.2 Check after Installation	42
6.3.3 Daily Checking.....	42
6.3.4 Weekly Checking	42

Table Index

Table 1-1: Specification List 1.....	11
Table 1-2: Specification List 2.....	12
Table 2-1: Parts List of Single-color Doser	17
Table 2-2: Parts List of Double Color Doser	19
Table 2-3: Parts List of High Temp. Doser.....	21
Table 2-4: Electrical Components List	26

Picture Index

Picture 1-1: Dimensions of Doser	10
Picture 2-1: Working Principle	15

Picture 2-2: Electrical Descriptions 1	22
Picture 2-3: Electrical Descriptions 2(Injection Mode).....	23
Picture 2-4: Electrical Descriptions 3(Extrusion Mode).....	24
Picture 2-5: Electrical Components Layout.....	25
Picture 2-6: Main Hopper.....	27
Picture 2-7: Mixing System	27
Picture 2-8: Heavy Base	28
Picture 3-1: Installation of Single Color Doser	29
Picture 3-2: Installation of Double Color Doser.....	29
Picture 4-1: Control Panel.....	31
Picture 4-2: Replace Dosing Screws	40

1. General Description



Please read this manual carefully before installation and using of the machine to prevent damage or personal injury.

The SCM series volumetric dosers are suitable for auto-proportional mixing of new materials, regrinds, master batch and additives. A gear motor with deceleration ratio of 38:1 is coupled to a dosing screw of 12, 16, 20, and 30mm diameter to offer ten models with different output ranging from 0.1 to 110kg/hr to clients. Double color doser can be assembled from any two single color doser according to clients' requirements. Five components automatic mixing can be realized if clients adopt four color doser.



Model: Single Color Doser SCM



Model: Double Color Doser SCM-D



High Temp. Doser SCM-H

1.1 Coding Principle

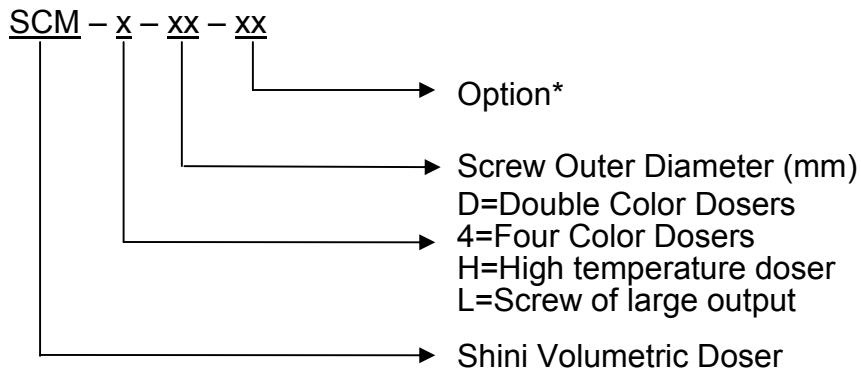

1.2 Features

- Dosing screws are chrome plated for durability.
- Unit is comprised of standard modules for ease of cleaning, disassembly and interchangeability.
- Hopper magnets are equipped in standard base to avoid molding machine screw damage.
- External signals can be directly input to control box.
- The current mode can be recorded without interrupted by power failure.
- Compulsory material cleaning makes it easier to replace masterbatch.
- Applicable on extrusion machines, just need to make a few wire replacements.
- Rotating speed can be automatically adjusted according to extruder processing speed, which maintains the fixed proportion of masterbatch.
- 50 recipes are available for permanent recording of material discharging time and finished products weight (for extruder, it is max. throughput per minute).
- Use brushless DC motor and free from maintenance.
- Both masterbatch blockage and overload can be detected, then machine will halt and sound an alarm.
- Based on customers demand, mold cycles can be set to add additives periodically so that micro-metering can be achieved.
- SCM-4 is standard equipped with a main hopper and a blender.
- Equipped with RS485 communication function (SCM-4 excluded).

1.3 Accessory option

- For collocating with SHD-100~300 or SHD-160U~450U dryers, heavy base should be selected.
- SCM-4 is capable of adding four kinds of masterbatch at most.
- High temperature doser SCM-H is optional for applying to PET high temperature situation; the water runs in its cooling part must be room temperature water.
- Blender is an option for customers to make materials evenly mixed.
- Main material hopper is optional equipment for customers to feed main material.
- Low level sensor can be opted to give an alarm when masterbatch is insufficient.
- Screws with diameter of 30mm can meet customers, requirements of large output.
- Optional 100Kg base to satisfy maximum discharge volume(without mixing function).

All service work should be carried out by a person with technical training or corresponding professional experience. The manual contains instructions for both handling and servicing. Chapter 6, which contains service instructions intended for service engineers. Other chapters contain instructions for the daily operator.

Any modifications of the machine must be approved by SHINI in order to avoid personal injury and damage to machine. We shall not be liable for any damage caused by unauthorized change of the machine.

Our company provides excellent after-sales service. Should you have any problem during using the machine, please contact the company or the local vendor.

Headquarter and Taipei factory:

Tel: (886) 2 2680 9119

Shini Plastics Technologies (Dongguan), Inc:

Tel: (86) 769 8111 6600

Shini Plastics Technologies India Pvt.Ltd.:

Tel: (91) 250 3021 166

1.4 Machine Specifications

1.4.1 Dimensions of Doser

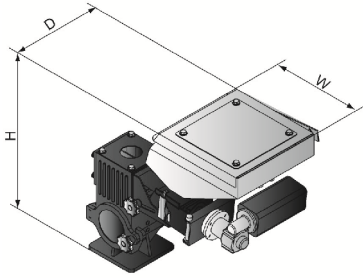

Single Color Doser

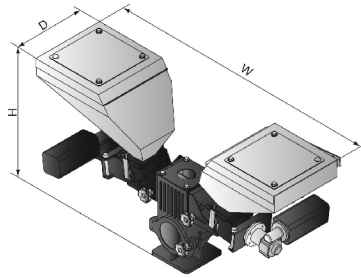

Double Color Doser

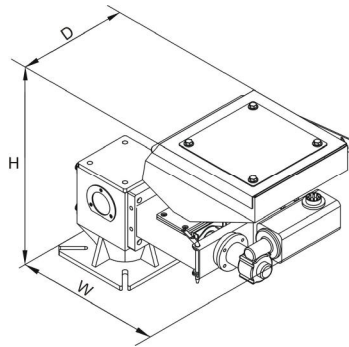

High Temp. Doser

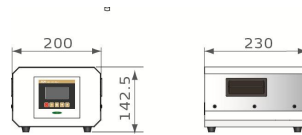

Controller

Picture 1-1: Dimensions of Doser

1.4.2 Specification List

Table 1-1: Specification List 1

Model	Single Color Unit				Double Color Unit
	SCM-12	SCM-16	SCM-20	SCM-30	SCM-D
Ver.	G	G	G	G	G
Motor Power (kW) (50/60Hz)	0.06	0.06	0.06	0.06	0.06 × 2
Output Power of Mixer (kW, 50 / 60Hz)	0.09	0.09	0.09	0.09	0.09 × 2
Screw External Dia. (mm)	12	16	20	30	**
Output Capacity (kg/hr)	0.1 ~ 10	0.5 ~ 30	3 ~ 60	8 ~ 110	*
Storage Hopper (L)	10	10	10	10	10
Gear Ratio	38:1	38:1	38:1	38:1	38:1 / 38:1
Main Material Hopper(L)	Optional (15)	Optional (15)	Optional (15)	Optional (15)	Optional (15)
Mixer	Optional	Optional	Optional	Optional	Optional
Floor Stand	Optional	Optional	Optional	Optional	Optional
Dimensions					
H (mm)	520	520	520	520	615
W (mm)	610	610	610	610	1045
D (mm)	335	335	335	335	410
Weight (kg)	29	29	29	29	50

- Note: 1) "*" stands for the output capacity depends on model selected, data of the single color doser can be a reference.
 2) "**" stands for external dia. of screw is up to model selected.
 3) For additional mixer, add "MS" at the end of model code.
 4) When selecting screws with diameter of 30mm, the machine model should be followed by "L" to distinguish it from other three kinds of interchangeable screws.
 5) All output capacities of above models are base on data from bulk density 1.2kg/L, dia. 2~3mm masterbatch in a test criteria of continuous running.
 6) Main power for single color unit is 1Φ, 115 / 230V, 50 / 60Hz, but it will be 3Φ, 230 / 400 / 460 / 575VAC, 50 / 60Hz when being equipped with mixer.

Table 1-2: Specification List 2

Model	SCM-H-12	SCM-H-16
Ver.	G	G
Motor Power (kW 50/60Hz)	0.06x2	0.06
Screw External Dia. (mm)	12	16
Output Capacity (kg/hr)	0.5~8	1.0~32
Storage Hopper (L)	10	10
Gear Ratio	38:1	38:1
Main Material Hopper(L)	Optional (15)	Optional (15)
Mixer	Optional	Optional
Floor Stand	Optional	Optional
Dimensions		
H (mm)	480	480
W (mm)	610	610
D (mm)	340	340
Weight (kg)	22	22

Note: 1) All output capacities of above models are base on data from bulk density 1.2kg/L, dia. 2~3mm masterbatch in a test criteria of continuous running.

2) Main power for single color unit is 1Φ, 115 / 230V, 50 / 60Hz, but it will be 3Φ, 230 / 400 / 460 / 575VAC, 50 / 60Hz when being equipped with mixer.

1.5 Safety Regulations

Strictly abide by the following safety guide to prevent damage of the machine or personal injuries.

1.5.1 Safety Signs and Labels



All the electrical components should be installed by qualified electricians.
Turn off the main switch and control switch during maintenance or repair.



Warning! High voltage!

This sign is attached on the cover of control box!



Warning! Be careful!

Be more careful at the place where this sign appears!



Attention!

No need for regular inspection because all the electrical parts in the control unit are fixed tightly!



Attention!

For high temp. doser SCM-H, it must be room temp. water that goes into the cooling part.



Warning!

Watch you hand!

The label sticks to the husing of the hopper!



Warning!

Be careful of scratch!

The label sticks to the coupling place of the screw and the measurement motor!

1.6 Exemption Clause

The following statements clarify the responsibilities and regulations born by any buyer or user who purchases products and accessories from Shini (including employees and agents).

Shini is exempted from liability for any costs, fees, claims and losses caused by reasons below:

1. Any careless or man-made installations, operation and maintenances upon machines without referring to the Manual prior to machine using.
2. Any incidents beyond human reasonable controls, which include man-made vicious or deliberate damages or abnormal power, and machine faults caused by irresistible natural disasters including fire, flood, storm and earthquake.
3. Any operational actions that are not authorized by Shini upon machine, including adding or replacing accessories, dismantling, delivering or repairing.
4. Employing consumables or oil media that are not appointed by Shini.

2. Structure Characteristics and Working Principle

2.1 Working Principle

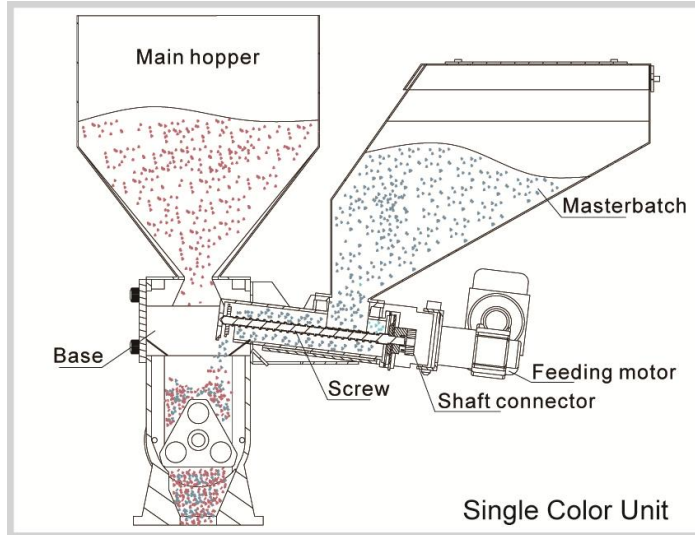

Picture 2-1: Working Principle

Signals from control cabinet will be sent to motor. Then motor begins to work. The rotary force is transferred to the dosing screw through shaft connector. Color additives in hopper will fall into the groove of conveying screw then be taken to hopper base by rotating action of the screw to achieve accurately meter and convey master batch.

2.2 Assembly Drawing and Parts List

2.2.1 Assembly Drawing of Single-color Doser

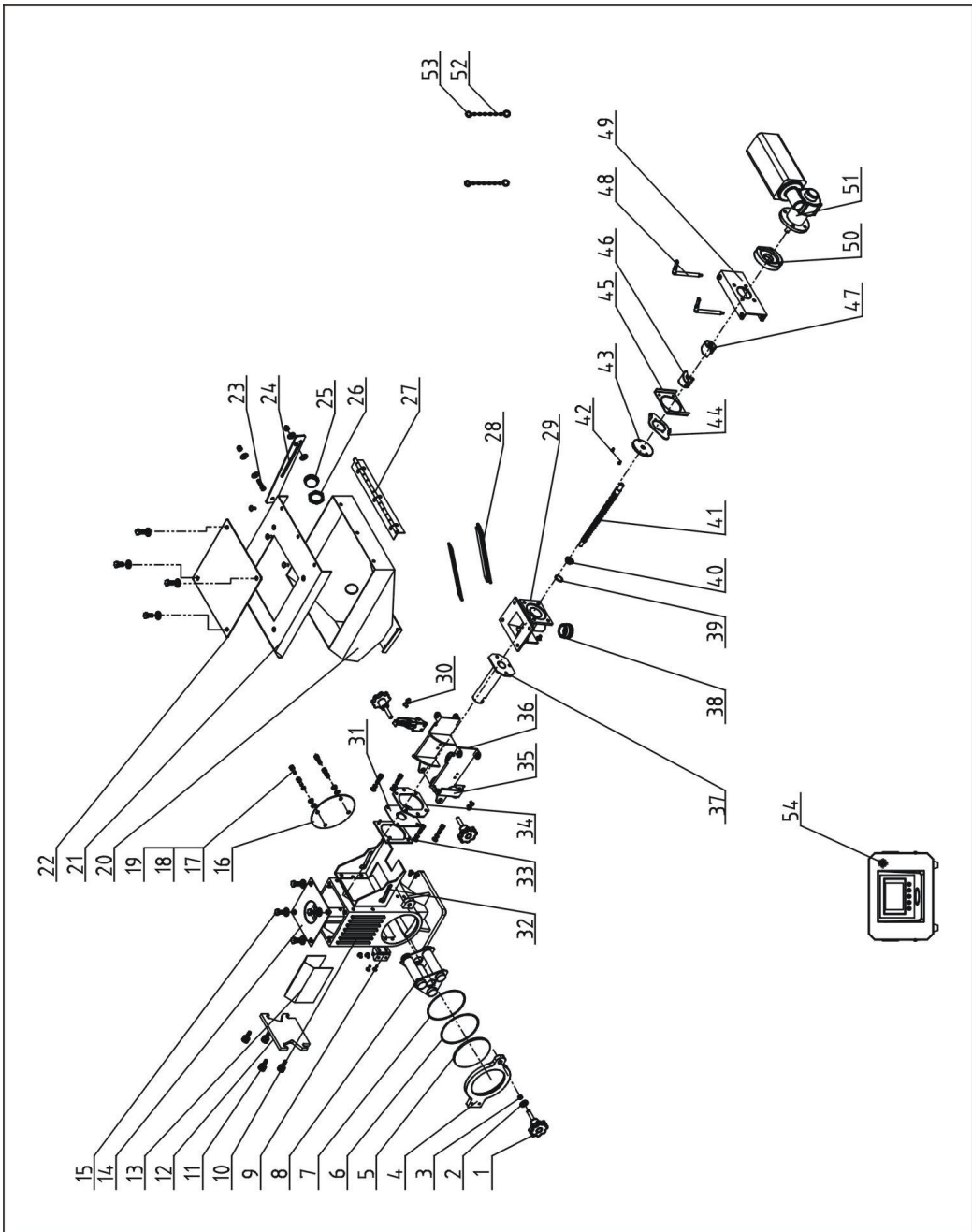

Note: Please refer to material List 2.2.2 for specific explanation of the Arabic numbers in parts drawing.

Picture 2-3: Assembly Drawing of Single-color Doser

2.2.2 Parts List of Single-color Doser

Table 2-1: Parts List of Single-color Doser

No.	Name	Part NO.	No.	Name	Part NO.
1	Star handle B M8×35	YR40084500000	31	Material keeping rubber (for screw 12)	YR10002600000
2	Flat gasket 8	YW66081900000		Material keeping rubber (for screw 16, 20)	YR10003600000
3	Hexagon nut M8	YW64000800100		Material keeping rubber (for screw 30)	YR10004700000
4	Base door	BW20387500210	32	Side fixed frame	--
5	Tempered glass *	YW70125000000	33	Material fender 1	--
6	Elastic ring for hole use GB893.1-86-98	YW69869800000	34	Material fender 2	--
7	O type seal ring	YR20162600100	35	New adjustable snap hook	YW02003000400
8	Three-tube magnetic frame	BY10500010050	36	Body fixed bracket 1	--
9	Hinge of magnetic base	YW09050200000	37	Doser screw □12 sleeve	BL31003804520
10	Base	BW20000000010		Doser screw □16 sleeve	BL31003804820
11	Manual tighten up M6×6×16	YW69616100000		Doser screw □20 sleeve	BL31003804720
12	End plate of doser	BH14129600010	38	Screw cap	BH10003800610
13	Doser material fender	-	39	Elastic ring for axes use GB/T 894.1 8	YW69008000200
14	Base cover	-	40	Doser screw fittings 2	BR90240801410
15	External hex screw M8×16	YW60081600100	41	□12 screw	YW09001200100
16	Rear cover	-		□16 screw	YW09001600100
17	Internal hex screw M6×20	YW61062000200		□20 screw	YW09002000000
18	Flat gasket 6	YW66061200000		□30 screw	YW09003000000
19	Spring gasket 6	YW65006000100	42	Flat head cross screw M3x6	YW61030600100
20	Storage hopper	-	43	Doser screw fittings 3	BR90387501510
21	Storage hopper lid	-	44	Screw connection plate	--
22	Storage hopper lid plate	BW09202000000	45	Doser conveying connection plate	--
23	Internal hex screw M6×25	YW61062500000	46	Shaft coupler 1	BH13001100110
24	Hopper connection plate	-	47	Shaft coupler 2	BH13001100210
25	Level sensor plug	BR30008400050	48	Motor fixed rotation pin	BH11003800610
26	Level sensor plug nut M30x1.5	YR30301500000	49	Body fixed bracket 2	--
27	Long hinge	YW06380300000	50	Feeding motor flange	BH13003200010
28	Visual window	BR90380400010	51	Gear motor *	YM50652500000
29	Conveying pipe (for screw 12, 16 and 20)	BL31003804920	52	Wire dia. 1.2 button **	YW90120000000
	Conveying pipe (for screw 30)	BL31003802110	53	Stainless steel key ring 1.2x16 **	YW00151300000
30	Cross socket head cap screw M4x10	YW62041000100	54	Control box assembly	--

* means possible broken parts. ** means easily broken part and spare a backup is suggested.

Please confirm the version of manual before placing the purchase order to guarantee that the item number of the spare parts is in accordance with the real object.

2.2.3 Assembly Drawing of Double Color Doser

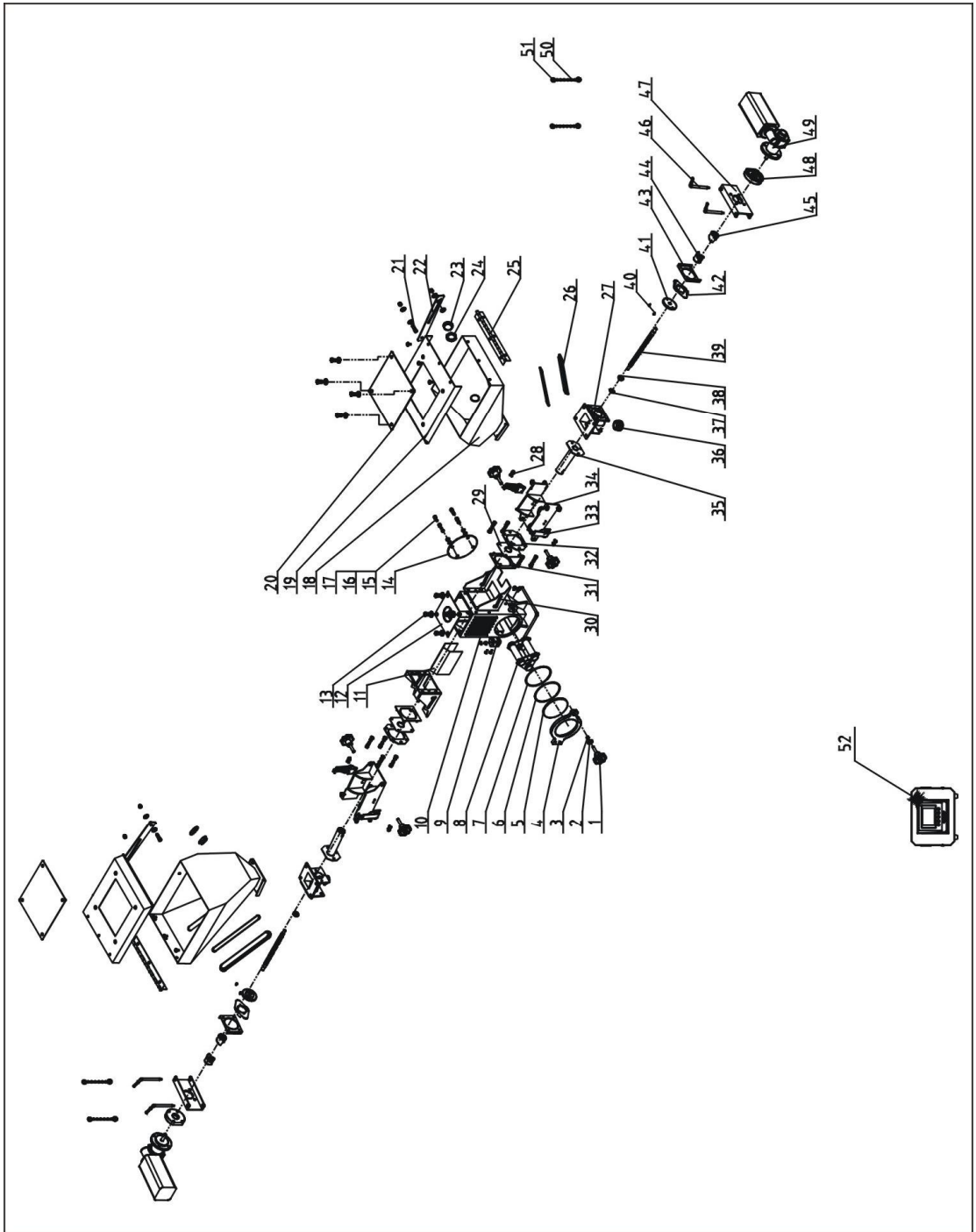

Notes: Please refer to material List 2.2.4 for specific explanation of the Arabic numbers in parts drawing.

Picture 2-3: Assembly Drawing of Double Color Doser

2.2.4 Parts List of Double Color Doser

Table 2-2: Parts List of Double Color Doser

No.	Name	Part NO.	No.	Name	Part NO.
1	Star handle B M8×50	YR40084500000	30	Material fender 1	--
2	Flat gasket 8	YW66081900000	31	Material fender 2	--
3	Hexagon nut M8	YW64000800100	32	Side fixed frame	--
4	Base door	BW20387500210	33	New adjustable snap hook	YW02003000400
5	Tempered glass *	YW70125000000	34	Body fixed bracket 1	--
6	Elastic ring for hole use GB893.1-86-98	YW69869800000	35	Doser screw □12 sleeve	BL31003804520
7	O type seal ring	YR20162600100		Doser screw □16 sleeve	BL31003804820
8	Three-tube magnetic frame	BY10500010050		Doser screw □20 sleeve	BL31003804720
9	Hinge of magnetic base	YW09050200000	36	Screw cap	BH10003800610
10	Base	BW20000000010	37	Elastic ring for axes use GB/T 894.1 8	YW69008000200
11	Doser material fender	--	38	Doser screw fittings 2	BR90240801410
12	Base cover	--	39	□12 screw	YW09001200100
13	External hex screw M8×16	YW60081600100		□16 screw	YW09001600100
14	Rear cover	-		□20 screw	YW09002000000
15	Internal hex screw M6×20	YW61062000200		□30 screw	YW09003000000
16	Flat gasket 6	YW66061200000	40	Flat head cross screw M3x6	YW61030600100
17	Spring gasket 6	YW65006000100	41	Doser screw fittings 3	BR90387501510
18	Storage hopper	-	42	Screw connection plate	--
19	Storage hopper lid	-	43	Doser conveying connection plate	--
20	Storage hopper lid plate	BW09202000000	44	Shaft coupler 1	BH13001100110
21	Internal hex screw M6×25	YW61062500000	45	Shaft coupler 2	BH13001100210
22	Level sensor	-	46	Motor fixed rotation pin	BH11003800610
23	Level sensor plug	BR30008400050	47	Body fixed bracket 2	--
24	Level sensor plug nut M30x1.5	YR30301500000	48	Feeding motor flange	BH13003200010
25	Long hinge	YW06380300000	49	Gear motor *	YM50652500000
26	Visual window	BR90380400010	50	Wire dia. 1.2 button **	YW90120000000
27	Conveying pipe (for screw 12, 16 and 20)	BL31003804920	51	Stainless steel key ring 1.2x16 **	YW00151300000
	Conveying pipe (for screw 30)	BL31003802110	52	Control box assembly	--
28	Cross socket head cap screw M4x10	YW62041000100			
29	Material keeping rubber (for screw 12)	YR10002600000			
	Material keeping rubber (for screw 16, 20)	YR10003600000			
	Material keeping rubber (for screw 30)	YR10004700000			

* means possible broken parts.

** means easily broken part and spare a backup is suggested.

Please confirm the version of manual before placing the purchase order to guarantee that the item number of the spare parts is in accordance with the real object.

2.2.5 Assembly Drawing of High Temp. Doser

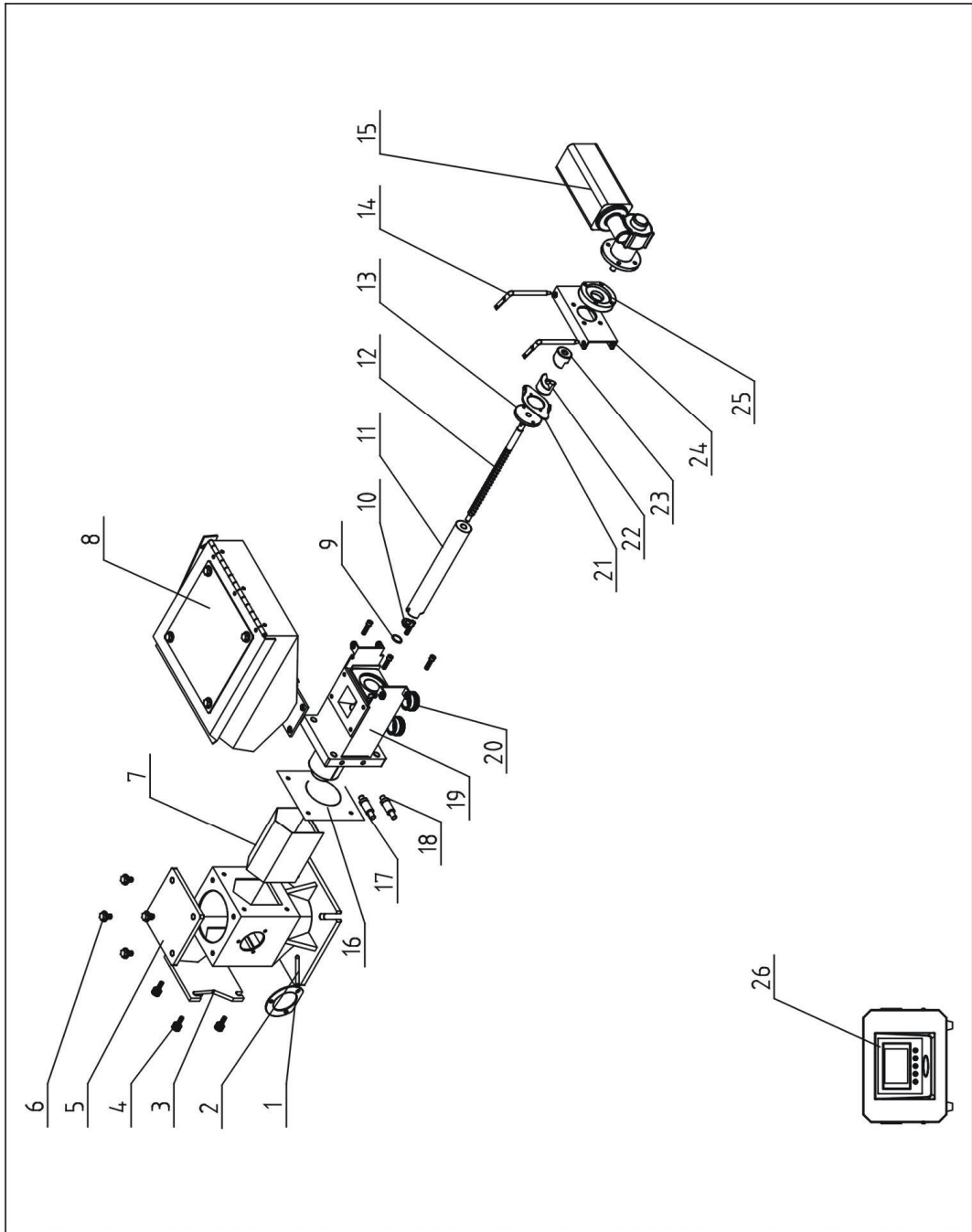

Notes: Please refer to material List 2.2.6 for specific explanation of the Arabic numbers in parts drawing.

Picture 2-3: Assembly Drawing of High Temp. Doser

2.2.6 Parts List of High Temp. Doser

Table 2-3: Parts List of High Temp. Doser

No.	Name	Part NO.	No.	Name	Part NO.
1	Filter screen	-	14	Motor fixing pin	BH11003800610
2	Base	-	15	Gear motor	YM50652500000
3	End plate of doser	BR90500200010	16	Material keeping rubber	--
4	Manual tighten up screw M6x6x16	YW69616100000	17	Water pipe quick connector with seal (Female plug)	YW59003800600
5	Cover plate	BR90000900110	18	Water pipe quick connector (Male plug) 1/8PT	YW59001800000
6	External internal hex screw M8x16	YW60081600100	19	Conveyor assembly	-
7	SCM material fender	-	20	Nut	BH10003800610
8	Storage hopper assembly	-	21	Screw connection strap	-
9	Elastic ring for axes use GB/T 894.1 8	YW69008000200	22	Shaft coupler 1	BH13001100110
10	SCM screw accessory 2	BR90240801410	23	Shaft coupler 2	BH13001100210
11	Screw sleeve 12	BR90001200010	24	Body fixed bracket 2	--
12	Screw 12	YW19001200700	25	Feeding motor flange	BH13003200010
	Screw 16	W19001600300	26	Control box	-
13	SCM screw accessory 3	BR90387501510			

* means possible broken parts.

** means easily broken part and spare a backup is suggested.

Please confirm the version of manual before placing the purchase order to guarantee that the item number of the spare parts is in accordance with the real object.

2.3 Electrical Circuit Descriptions

2.3.1 Electrical Descriptions

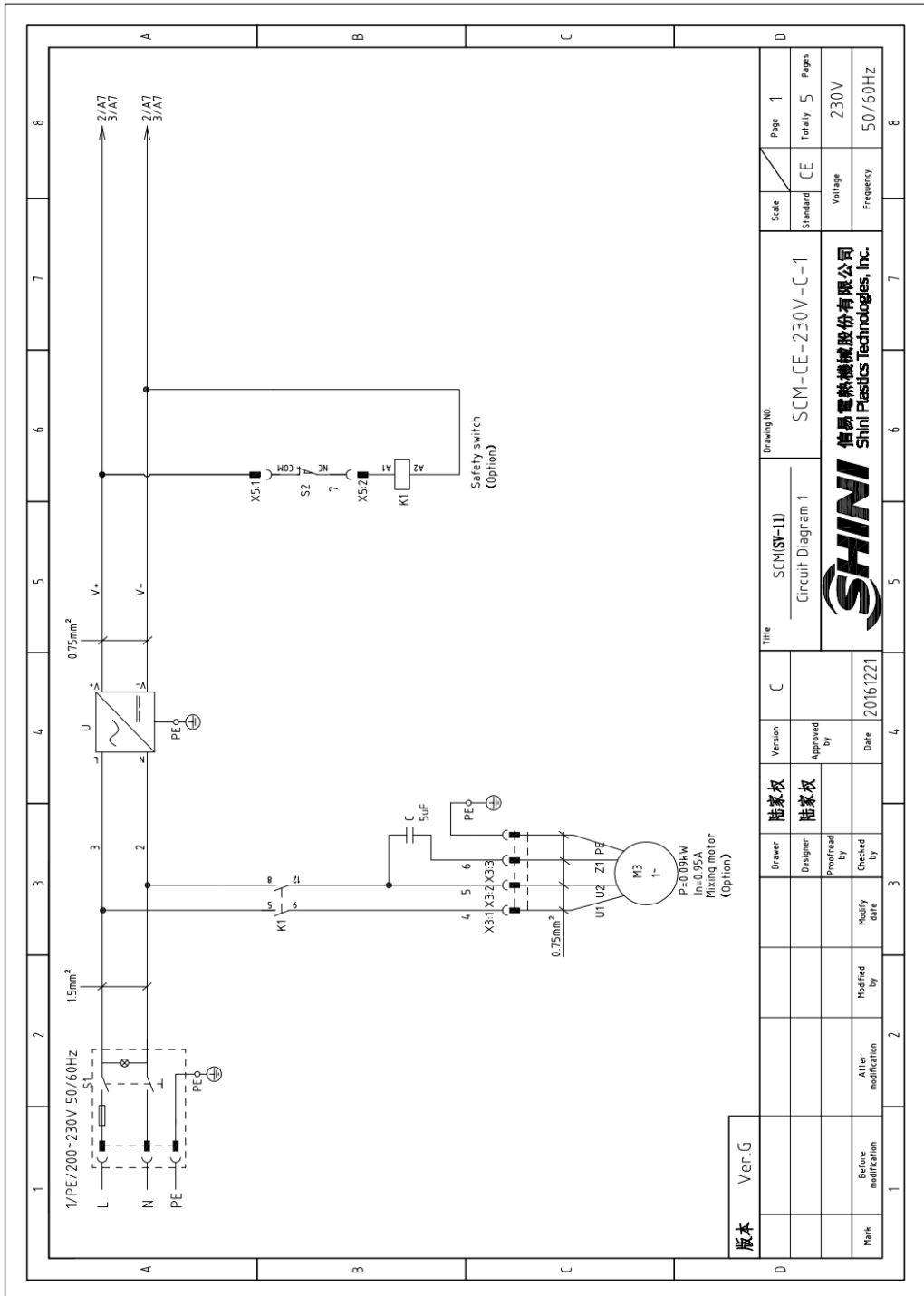

Picture 2-2: Electrical Descriptions 1

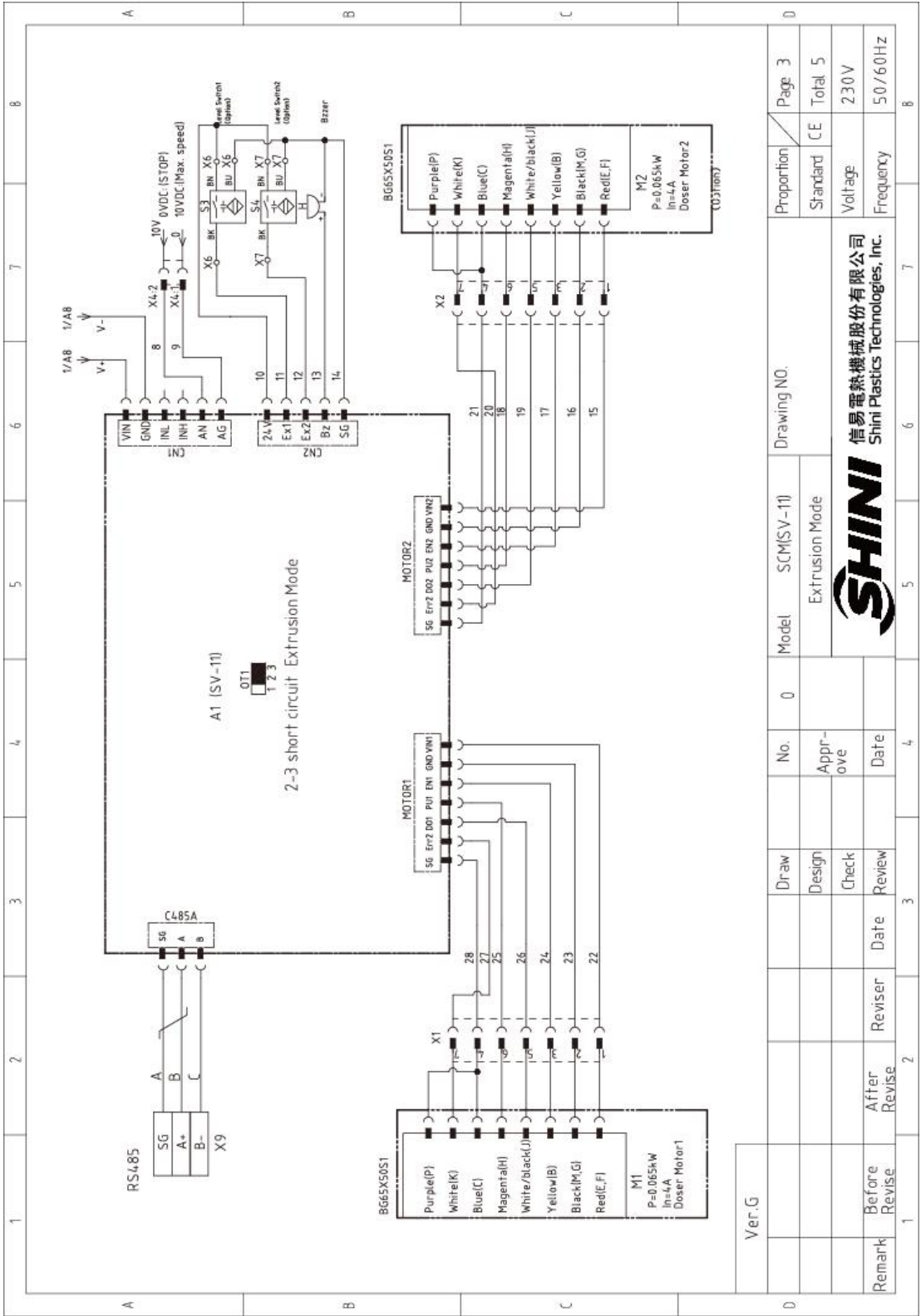

Picture 2-4: Electrical Descriptions 3(Extrusion Mode)

Ver.G	No. 0	Model	SCM(SV-11)	Drawing NO.	Proportion	Page 3
	Design	Check	Extrusion Mode		Standard	Total 5
Remark	Before Revise	After Revise	Date	Date	Voltage	230V
					Frequency	50/60Hz

SHINI
 信易電熱機械股份有限公司
 Shini Plastics Technologies, Inc.

2.3.2 Electrical Components Layout

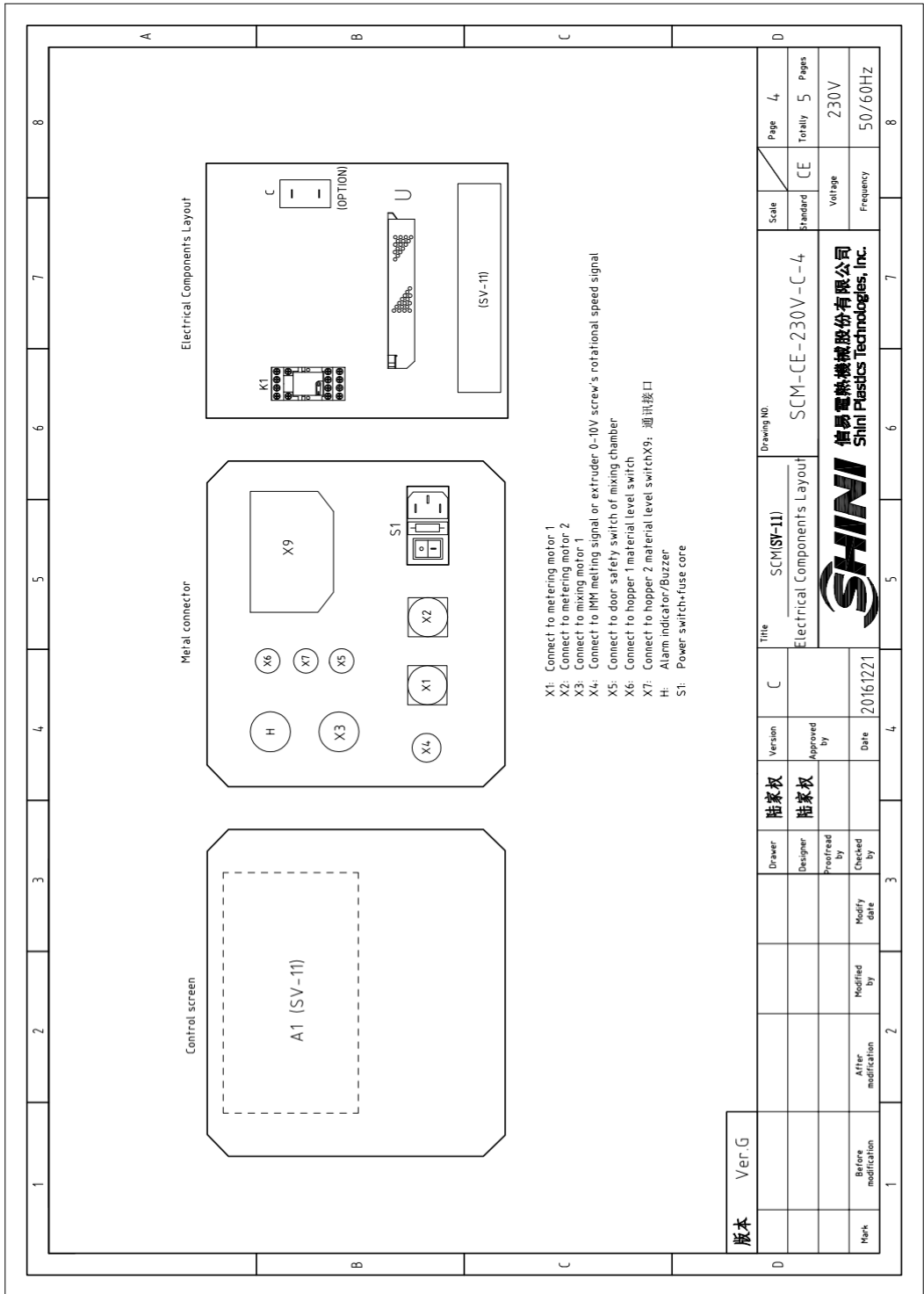

Picture 2-5: Electrical Components Layout

2.3.3 Electrical Components List

Table 2-4: Electrical Components List

1		2		3		4		5		6		7		8	
No.	Symbol	Name	Manufacturer	Type	Specification	Number	Material number	Remark							
1	A1	PCB	YUYUN	SV-11 (24VDC)	24VDC	1	YE60112400500								
2	S1	Power switch+plug cable	MISUMI	APCI-101-1FR-03	Alternative switch+power plug-in LAC90-56A-53-375-21	1	YE1511300000								
3		Fuse	SHINI	5x20	10A 250V	1	YE46010250000								
4		CE Power Line	---	1.0x3PI(Wire length 3m)	10A	1	YE50122500000	☑							
5		GB Power Line	---	0.75x3PI(Wire length 3m)	16A	1	YE50316300000	☑							
6	H	Buzzer	HITPOINT	PK-27A	24VDC	1	YE84002700000								
7	U	DC Power	MW	HRP-150-24	IN=115/230V OUT=24VDC 6.5A	1	YE71246500000								
8	X1 X2	Metal joint	PLT	PLS-24,10-RF-PM	10P	2	YE6224,104,00000								
9	X3	Metal joint	PLT	PLT-25L-PM	4P	1	YE680254,00000	(2)							
10		Metal joint	PLT	PLT-25L-RF	4P	1	YE680254,00100	(2)							
11	X4	Metal joint	PLT	PLT-162-RM/PLT-162-PF	2P	1	YE68016200100/YE68016200000								
12	X5	Metal joint	PLT	PLT-162-RM/PLT-162-PF	2P	1	YE68016200100/YE68016200000	(2)							
13	X6 X7	Metal joint	PLT	ADF-16	3P	2	YE6216304,00000/YE62163000100	(3)							
14	K1	Middle relay	WEIDEMULLER	DRM270024LT	24VDC	1	YE03272400000	(2)							
15	S2	Micro switch	TEND	TZ-3102	250V~5(A)	1	YE16310200000	(1) (2)							
16	S3 S4	Capacitance switch	IFM	K15082	10~36VDC	2	YE15508200000	(1) (3)							
17	M1	Motor	ALCTEL	BG65 138	65W 24VDC	2	YM50652500000	(1)							
18	M2	Motor	ALCTEL	BG65 138	65W 24VDC	2	YM50652500000	(1) (4)							
19	M3	Motor	JSEC	---	0.09KW 1/230V 50/60HZ	1	---	(1) (2)							
<p>版本 Ver.G Notes: (1)Means it's not the material inside the control box.(2)Means accessories for mixing motor.(3)Stand for level switch option.(4)Stand for double shooter option .</p>															
D		Title		Drawing NO.		Scale		Page		Standard		Voltage		Frequency	
		SCM(SF-11)		SCM-CE-230V-C-5		CE		5		CE		230V		50/60HZ	
Mark		After modification		Modified by		Modify date		Checked by		Date		SHINI 德易電熱機械股份有限公司 Shini Plastics Technologies, Inc.		8	
						20161221									

2.4 Optional Accessories

2.4.1 Main hopper

The main material hopper is optional for both single and double color doser basing on customer demand.

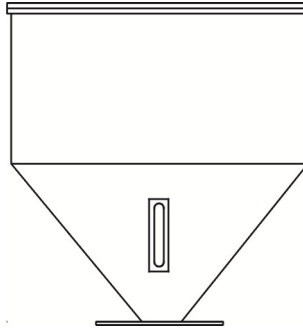

Picture 2-6: Main Hopper

2.4.2 Mixing System

The mixing system is optional for both single and double color doser basing on customer demand.

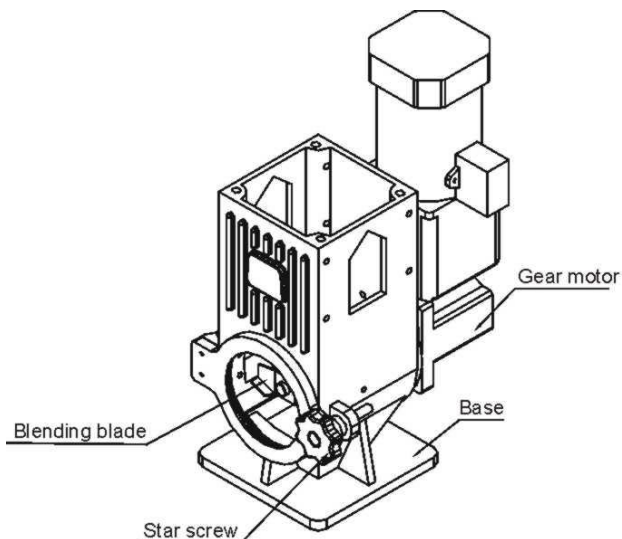

Picture 2-7: Mixing System

2.4.3 Heavy base

When customer requires SHD-100~300kg or SHD-160U~450U dryer, this heavy base is necessary.

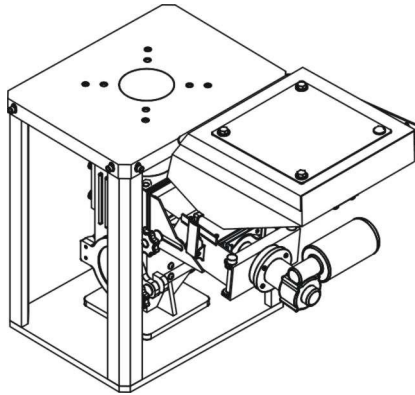

Picture 2-8: Heavy Base

3. Installation and Debugging

Read this chapter carefully before installation. Install the machine by following steps.

This series of models only could be applied in working environment with good ventilation.



Power supply of the machine should be done by qualified electricians!

3.1 Install on Extrusion or Injection Molding Machine

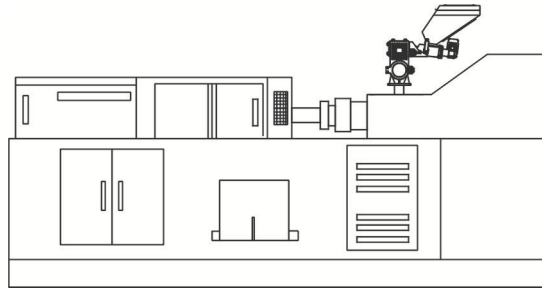

Picture 3-1: Installation of Single Color Doser

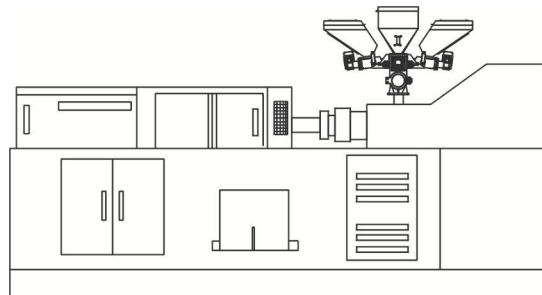

Picture 3-2: Installation of Double Color Doser

According to the specifications of mounting holes on the extruder or injection molding machine, drill 4 screw holes on the base of SCM machine. Install the whole machine on the extruder or injection molding machine by locking the 4 screw holes of mounting base.

3.2 Power Supply Wiring

Please select correct voltage and adjust the controller power to corresponding voltage before the Doser operation.

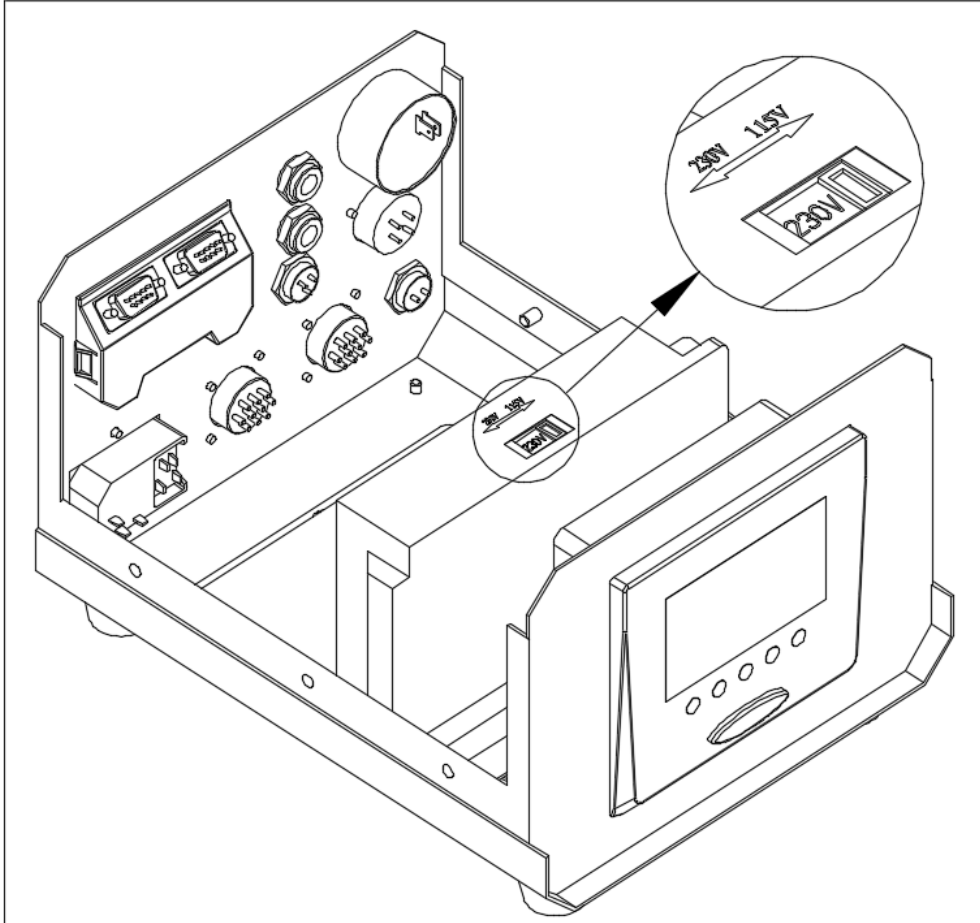

4. Operation

4.1 Control Panel (SCM)

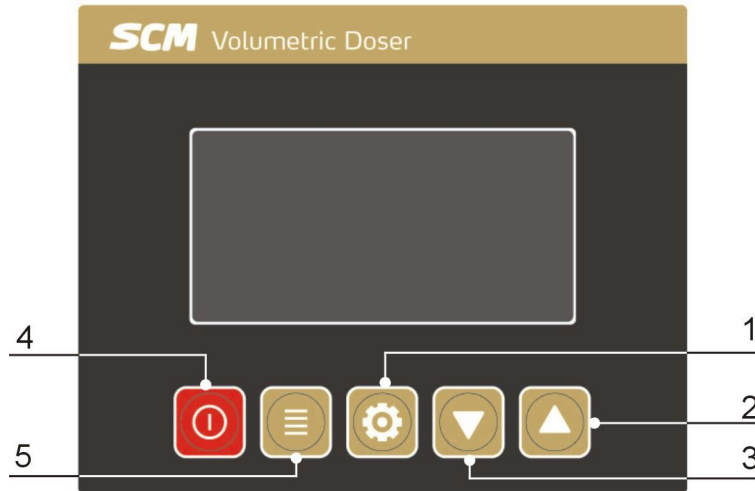

Picture 4-1: Control Panel

1. Setting key 2. Up key 3. Down key 4. Switch 5. Menu key

Chinese/English selection: Power on the machine, press the setting key  for 3 secs. to switch English/Chinese.

4.2 Start/Stop of the Machine

- 1) Check whether the power is turned on.
- 2) Turn on the main switch at the back of control box.
- 3) Press the control switch on the panel, the RUN indicator will be turned on.
- 4) After the setting of parameters is finished, machine will operate automatically if Extruder start to run and signals get into the doser.
- 5) Follow the reverse order to turn off.

4.3 Operation Instruction

Three states of machine.



The indicator has three states:

Yellow: Standby

Green: Run

Red: Alarm

4.3.1 IMM Mode Setting

According to circuit diagram (J1 connects pin 1-2), when connection is in IMM mode (it receives IMM 24VDC melt signal), the machine is at IMM mode after power on.

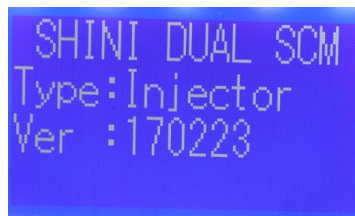

4.3.1.1 Parameters Set for IMM Mode

1. 50 secs. weight setting steps:

- 1) Press Menu key  till it enters the screen displaying 50 secs. weight output of screw 1.





- 2) Hold on the Setting key  for 5 secs, and it enters the screen displaying manual feeding of screw 1.



No.1 Filling
No.1 time:9953s

- 3) Press Menu key  to start feeding of screw No.1

- 4) Press Setting key , it enters screw 1 50 secs. output testing screen



50secs .testing
No.1 time:0456s

- 5) Press Menu key  to test screw 1 50 secs. output weight. After 50 secs., it enters screw 1 50 secs. weight input screen. Input the masterbatch weight output by screw in 50 secs. into corresponding place. The default is 50.



H1 50s weight
Range :01-9999g
Before:0500
After :050

- 5) Press Menu key , save the setting and exit.



Note: For double shooter, the 50 secs. output setting of screw 2 is same as screw 1.

2. IMM Melting Time Setting

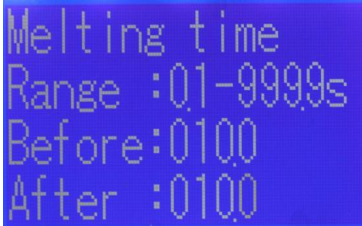
- 1) Press Menu key  till it displays melting time setting screen as below:



```
Melting time
Range :01-9999s
Before:0100
After :0100
```

- 2) Press setting key  to shift the digital. Adjust the number by  and  key. Set melting time, its default is 10 secs.

- 3) Press Menu key , save the setting and exit.

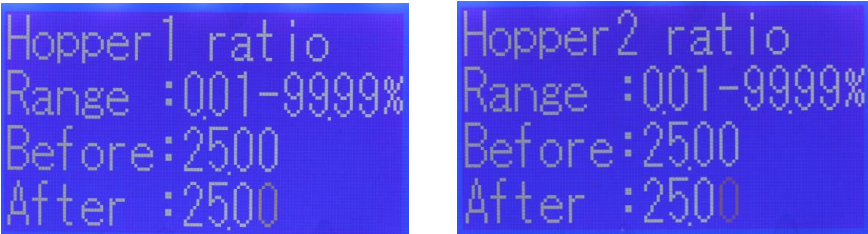

3. Masterbatch Proportion Setting

- 1) Press Menu key  till it displays screw 1 and 2 proportion setting screen



```
Hopper1 ratio
Range :001-9999%
Before:2500
After :2500

Hopper2 ratio
Range :001-9999%
Before:2500
After :2500
```

- 4) Press setting key  to shift the digital, and adjust the number by  and  keys. Set proportion of screw 1 and 2. Setting proportion of screw 1 is 2%. When it uses two ingredients, the proportion of screw 2 is set as 3%.

- 5) Press Menu key , save the setting and exit.

4. Weight per Mould Setting

Press menu key  till it displays weight per mould screen. Input the product actual weight, and the default is 100g.

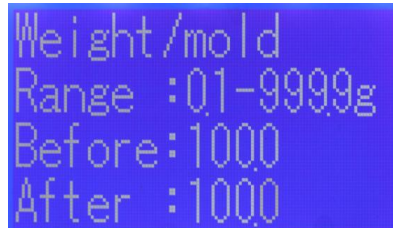

After above settings, turn on the main switch . The machine will feed the masterbatch and additives in time according to IMM's melting signal.

Note: In this step, the input weight unit is consistent with that of the 50S measured value. For example, if the input unit is g (10g, 100g, kg...) in 50S test, then the input unit is g (10g, 100g, kg...).

4.3.2 Extruder Mode

According to circuit diagram (J1 short connects with pin 2-3 on board). When connection is in extruder mode (it receives signal 0~10V from extruder), and the machine is at extruder mode after power on.

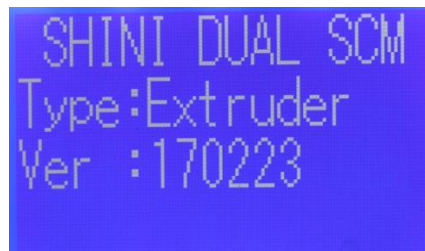

4.3.2.1 Parameters Set for Extruder Mode

1. 50 secs. weight setting steps:
Setting steps are the same as IMM
2. Masterbatch proportion setting
Setting steps are the same as IMM
3. Extruder max. output setting:

- 1) Press Menu key  till it displays extruder max. output setting screen as below:

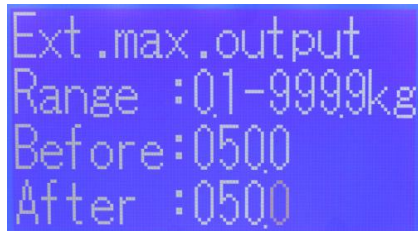

```
Ext.max.output
Range :01-9999kg
Before:0500
After :0500
```

Set hourly max. output during extruder operation. The default is 50Kg/H.

- 2) Press menu key , save the setting and exit.

After above settings, turn on the main switch . The machine will feed the masterbatch and additives proportionally according to extruder signal (0~10V).

4.3.3 Other Function Setting

1. Micro-metering Method (only for IMM).

Function: When each mould only requires a few masterbatches (less than 0.5g), it can use this function. Set discharge cycle as 2, which means once master discharge in twice IMM signals, and so on.

Setting steps: After setting the 50 secs. output value, masterbatch proportion, weight per mould and melting time according to IMM mode, press Menu key

 till it displays discharge cycle screen as below. Change the discharge cycle, then the setting is finished. The default is 1.

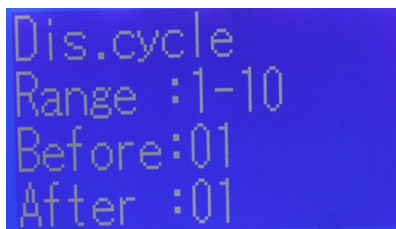

```
Dis.cycle
Range :1-10
Before:01
After :01
```

2. Color Compensation Mode

Function: When screw feeds regrind, it can add the masterbatch in proportion only to the regrinds. Total masterbatch that the screw fed equals to original

required amount plus regrind required amount. The default is 0.



```
H2 clr.com.ratio
Range :0-9999%
Before:1000
After :1000
```

3. Screw 2 Optional Level Switch Mode

Function: When hopper of screw 2 options with level switch that detects the low level during operation, screw 2 will stop metering. Insufficient regrinds will be fed by basterbatch and material proportionally and automatically.

4.3.4 Other Parameters Function

1. Control type (0~3 for selection for IMM mode, the default is 0):

0--- External signal & setting time

1--- External signal: when Doser works, the signal is determined by external signal.

2--- Melting time: When Doser works the signal is determined by set signal of melting time.

3---External signal: When Doser works, the signal is determined by previous mould received signal of melting time.

When the setting is 0, it means feeding time of Doser screw is determined either by external signal or set melting time, depending on whose lasting time is shorter. Such as: When IMM motion signal ended but Doser set melting time still on, Doser screw will stop feeding. When IMM motion signal lasts but Doser set melting time is over, Doser screw will stop feeding too.

When the setting is 1, Doser screw won't stop feeding unless external signal breaks.

When the setting is 2, Doser screw stops feeding when melting time is over.

When the setting is 3, it drives the screw according to previous mould received melting time.

```
Control type
Range :0-3
Before:0
After :0
```



2. Motor Failure Alarm Setting:

```
Motor1 failure
Range :HorL
Before:L
After :L
```

Note: Metering motor alarm method: L: level alarm, H: high level alarm.
Motor used by company is low level alarm, the default is L.

3. Setting for Communication with Upper Unit

```
SHINI DUAL SCM
Type:Injector
Ver :170223
```

After it enters above start screen, hold on  and  together for 3 secs.
It enters parameter setting for communication. When communicating with upper unit, the machine should set parameters as below:

```
Station N.
Range :1-99
Before:01
After :01
```

```
Baud rate
Range :0-3
Before:1
After :1
```

```

Odd/even cal.
Range :0-2
Before:2
After :2
    
```

```

Stop bit
Range :1-2
Before:1
After :
    
```

F26: Station No.	1~99
F27: Baud Rate	0: 4800 1: 9600 2: 19200 3: 38400
F28: Odd-even Check	0: No 1: Even 2: Odd
F29: Stop Bit	1: 1bit 2: 2bit

4. Metering Motor Output

```

Motor output
Range :1-2
Before:2
After :2
    
```

Note: For single ingredient, the metering motor outputs 1; For double ingredients, the metering motor outputs 2.

4.4 Replace Dosing Screws

- 1) Cut off power supply, loosen snap hook of the hopper, draw out the hopper and screw. Then unlock the screw fastening plate to remove the conveying screw for replacement. During screw replacement, it should replace the sleeve simultaneously (different screw diameters are matching different sleeves).
- 2) Install the screw and hopper back to the machine.

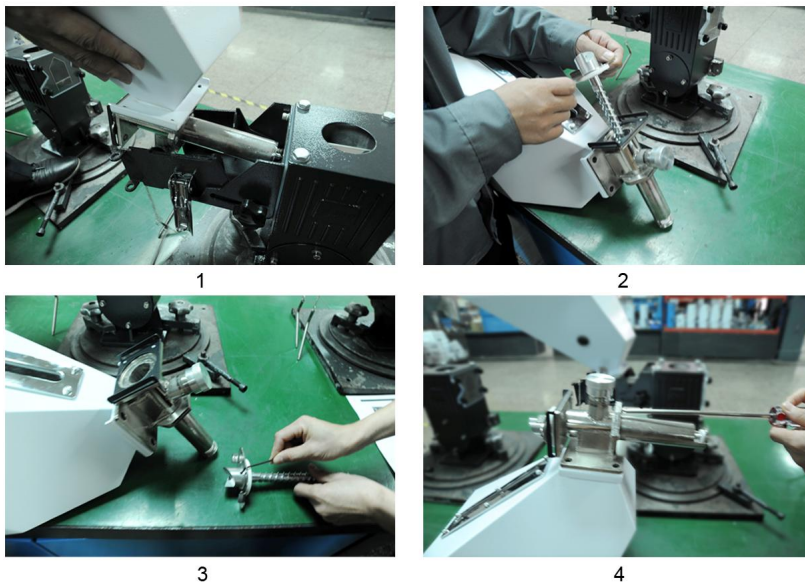

Picture 4-2: Replace Dosing Screws

5. Trouble Shooting

Failures	Possible reasons	Solutions
No indicates on the control cabinet.	1. Power supply not connected.	1. Connect the power supply.
	2. Fuse burnt out or control board problems	2. Replace the fuse or check control board.
Motor does not work.	1. Parameter mistakes.	1. Reset parameters.
	2. Motor overload.	2. Contact the manufacturer or local distributor.
	3. Motor damaged.	3. Replace the motor.
	4. Signal wire broken.	4. Replace motor signal wire.
	5. Signal wire connection wrong	5. Conduct Inspection
The buzzer sounds the alarm.	Parameter setting exceeds the limit.	Reset parameters.

6. Maintenance and Repair

6.1 Repair

All the repair work should be done by qualified technicians to prevent personal injuries and damage of the machine.

6.2 Maintenance

Keep the surface of machine clean.

6.3 Maintenance Schedule

6.3.1 About the Machine

Model _____ No. _____ Manufacturing date : _____

Voltage _____ Φ _____ V Frequency _____ Hz Total power: _____ kW

6.3.2 Check after Installation

- Check that dosing screws are fitted correctly.
- Check the snap hook is tightly locked.
- Check if the mounting base is firmly locked.

Electrical Installation

- Voltage: _____ V _____ Hz
- Fuse melt current: 1 Phase _____ A 3 Phase _____ A
- Power supply and signal wire of control cabinet are correctly connected.

6.3.3 Daily Checking

- Check the main switch.
- Check fastening screws of mounting base.

6.3.4 Weekly Checking

- Check if there damaged electrical wires.
- Check snap hooks are loose or not.
- Check if the side holding plate is loose or not.