

1. Assembly Drawing (SG-23)

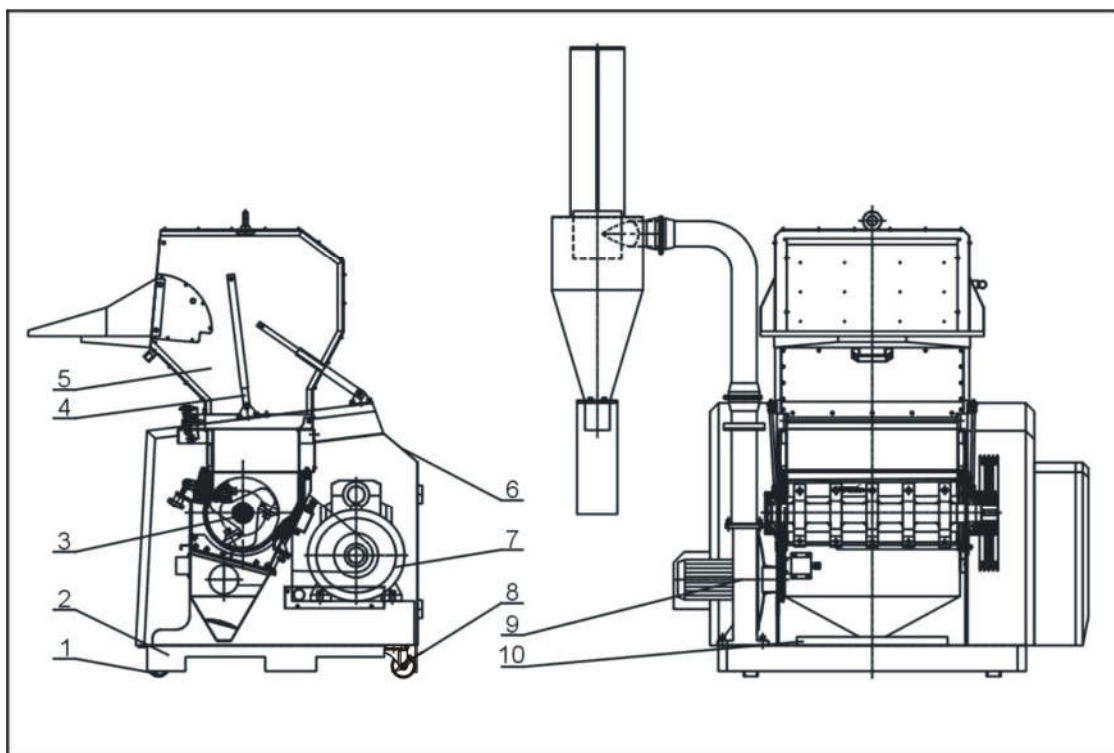

Note: Please refer to 2 material list about the parts code.

2. Parts List (SG-23)

No.	Name	Part No.		
		SG-2324	SG-2336	SG-2348
1	Fixed castor 3"	YW03000300500	YW03000300500	YW03000300500
2	Machine rack	-	-	-
3	Cutting chamber	-	BH85433600010	BH85234800610
4	Elastic gasket	YW01050000100	YW01060000100	YW01060000100
5	Feed box	-	-	-
6	Shield parts	-	-	-
7	Main gear	-	-	-
8	Side brake of Movable castor 3"	YW03000300900	YW03000300900	YW03000300900
9	Automatic feed	-	-	-
10	Presetting knife jig	-	-	-

Please confirm the version of manual before placing the purchase order to guarantee that the item number of the spare part is in accordance with the real object.

3. Main Gear(SG-23)

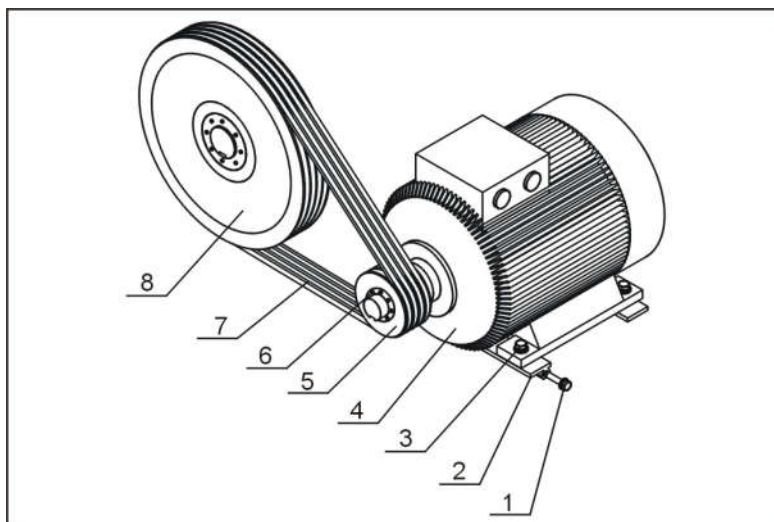

Note: Please refer to 4 material list about the parts code.

4. Parts List of Main Gear (SG-23)

No.	Name	Part No.		
		SG-2324	SG-2336	SG-2348
1	Hexagon head screw M10×80	YW60108000000	YW60108000000	YW60108000000
2	Motor control board	BH10236100010	BH10236100010	BH10306500110
3	Hexagon head screw	YW60104000100	YW60104000100	YW60124500000
4	Motor	YM10713000500	YM10137500000	YM10716300300
5	Motor belt pulley	BW30002305320	BW30002305320	BW30002305320
6	Belt pulley taper sleeve	BW30003005320	BW30003005320	BW30003005320
7	Triangle belt	YR00160000100	YR00160000100	YR00160000100
8	Big wheel	BW30002305220	BW30002305220	BW30002305220
9	Big wheel sleeve	BW30023005320	BW30023005320	BW30023005320

Please confirm the version of manual before placing the purchase order to guarantee that the item number of the spare part is in accordance with the real object.

5. Cutting Chamber (SG-23)

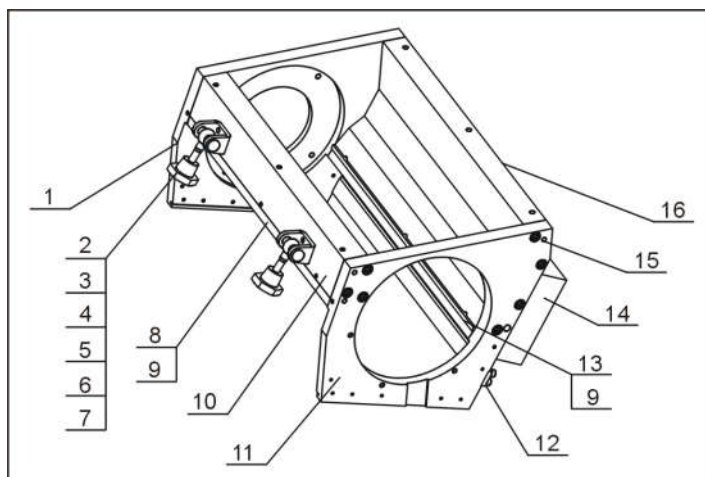

Note: Please refer to 6 material list about the parts code.

6. Parts List of Cutting Chamber (SG-23)

No.	Name	Part No.		
		SG-2324	SG-2336	SG-2348
1	Left side plate	BH10232500010	BH10232500010	BH10232500010
2	Hinge base	-	-	-
3	Shaft pin	YW09301400000	YW09301400000	YW09301400000
4	A type circlip for shaft 16	YW69001600000	YW69001600000	YW69001600000
5	Star screw	YW09003010500	YW09003010500	YW09003010500
6	Flat gasket	YW66123200100	YW66123200100	YW66123200100
7	Star nut (M12)	YW09001200500	YW09001200500	YW09001200500
8	Front pressing block	BW30232400110	BW30233600110	BW30234800110
9	Fixed blades	BW40232400040	YW42233600100	YW42234800100
10	Front block	-	BW30233600010	BW30234800010
11	Right side plate	BH10231100010	BH10231100010	BH10231100010
12	Screen bracket fixing plate	-	-	-
13	Back pressing block	BW30232400410	BW30233600410	BW30234800410
14	Water tank	-	-	-
15	Elastic fixing pin 8×35	YW69083500000	YW69083500000	YW69083500000
16	Rear box block		BH10236500010	BH10230800010

Please confirm the version of manual before placing the purchase order to guarantee that the item number of the spare part is in accordance with the real object.

7. Cutting Chamber Two (SG-23)

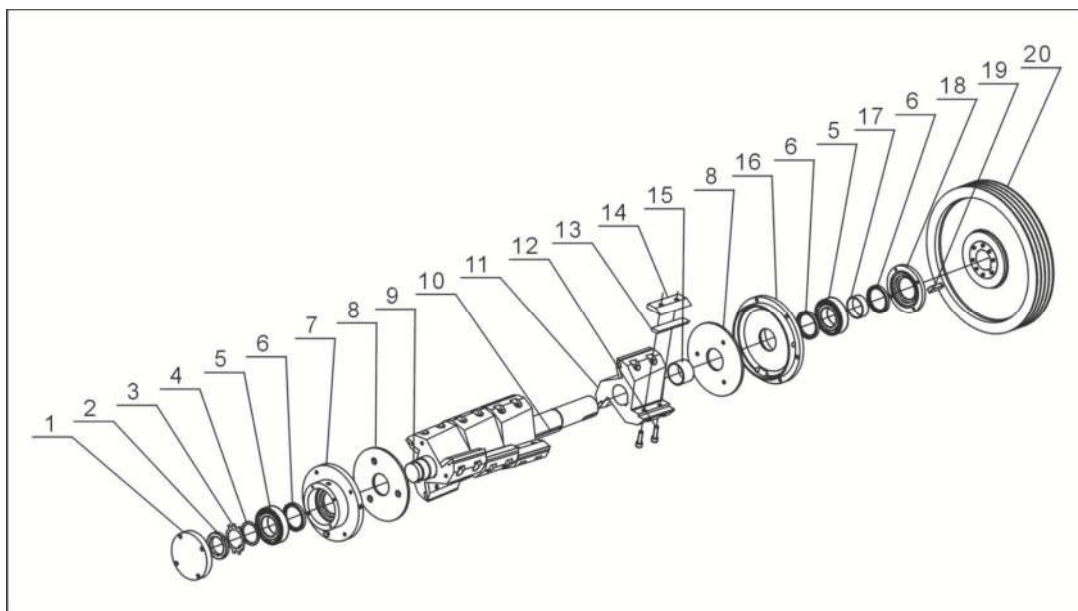

Note: Please refer to 8 material list about the parts code.

8. Parts List of Cutting Chamber Two (SG-23)

No.	Name	Part No.		
		SG-2324	SG-2336	SG-2348
1	Left bearing block cover plate	BH10232700010	BH10232700010	BH10232700010
2	Round nut M52×1.5	YW65215000000	YW65215000000	YW65215000000
3	Lock gasket 52	YW09521600000	YW09521600000	YW09521600000
4	Bearing gasket	-	-	-
5	Self-aligning roller bearing 22211C	YW11222100600	YW11222100600	YW11222100600
6	Oil seal 75×60×8	YR80756000000	YR80756000000	YR80756000000
7	Left bearing block	BH10232600010	BH10232600010	BH10232600010
8	Material fender	YW45230000000	YW45230000000	YW45230000000
9	Shaft	-	BH10236600010	BH11236200010
10	Flat key 16×10×L	BH10232410010	BH10233610010	BH10234810010
11	Blade rest	-	-	-
12	Inner hexagon cylindrical screw M10×40	YW61104000200	YW61104000200	YW61104000200
13	Rotary blades	YW42023001000	YW42023001000	YW42023001000
14	Rotary blades pressing plate	BH10125000010	BH10125000010	BH10125000010
15	Shaft sleeve 1	BH10231900010	BH10231900010	BH10231900010
16	Right bearing block	BH10231200010	BH10231200010	BH10231200010
17	Shaft sleeve 2	BH10231400010	BH10231400010	BH10231400010
18	Right bearing block cover plate	BH10232300010	BH10232300010	BH10232300010
19	Flat key 16×10×50	BH10231500010	BH10231500010	BH10231500010
20	Big wheel	BW30002305220	BW30002305220	BW30002305220
21	big wheel sleeve	BW30023005320	BW30023005320	BW30023005320

Please confirm the version of manual before placing the purchase order to guarantee that the item number of the spare part is in accordance with the real object.

9. Screen (SG-23)

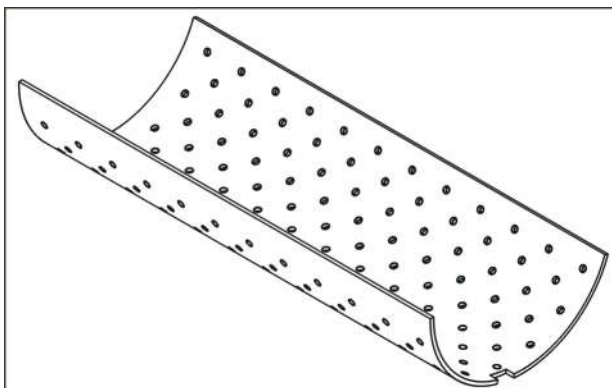

10. Parts List of Screen (SG-23)

No.	Name	Part No.		
		SG-2324	SG-2336	SG-2348
1	Screen 8mm	BL54232400820	BL54233600820	BL54234800820

Please confirm the version of manual before placing the purchase order to guarantee that the item number of the spare part is in accordance with the real object.

11. Feed Box(SG-23)

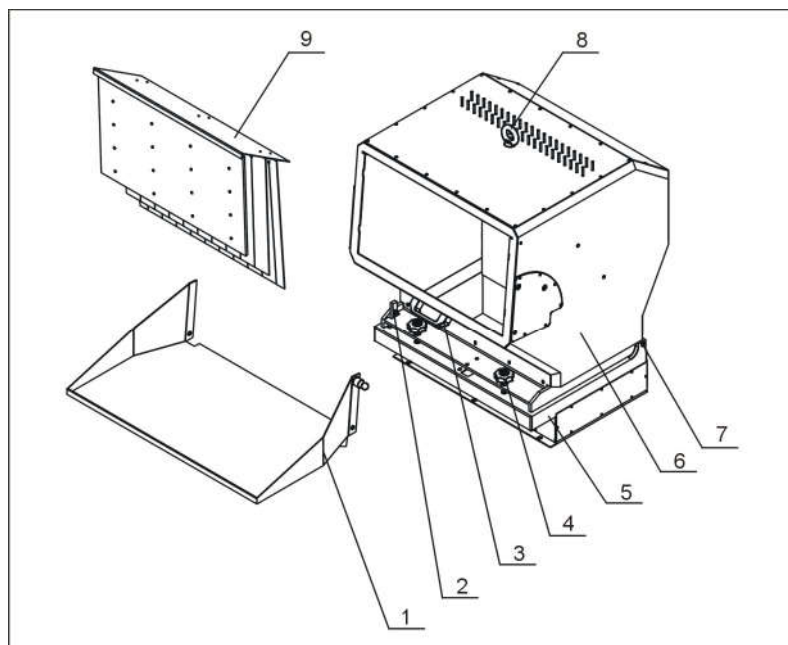

Note: Please refer to 12 material list about the parts code.

12. Parts List of Feed Box(SG-23)

No.	Name	Part No.		
		SG-2324	SG-2336	SG-2348
1	Feed port	-	-	-
2	Pothook	-	-	-
3	Aluminum square handle L120	BW20012000140	BW20012000140	BW20012000140
4	Star screw combination	BH11300200010	BH11300200010	BH11300200010
5	Cutting chamber	-	-	-
6	Feed box	-	-	-
7	Feed box shaft	-	-	-
8	Lifting screw M16	YW09001600000	YW09001600000	YW09001600000
9	Material fender assembly	-	-	-

Please confirm the version of manual before placing the purchase order to guarantee that the item number of the spare part is in accordance with the real object.

13. Automatic Feeding Assembly (SG-23)

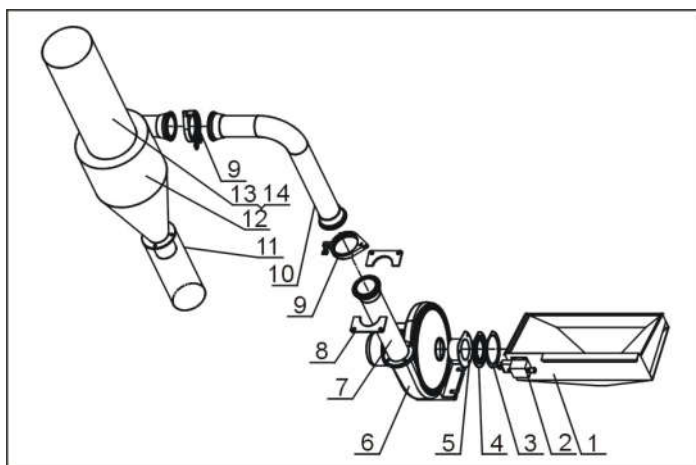

Note: Please refer to 14 material list about the parts code.

14. Parts List of Automatic Feeding Assembly (SG-23)

No.	Name	Part No.		
		SG-2324	SG-2336	SG-2348
1	Storage box	-	-	-
2	Spiral switch	-	-	-
3	Pressing plate	-	-	-
4	Material inlet fastener	YR10002300000	YR10002300000	YR10002300000
5	Blower suction port connecting pipe	-	-	-
6	Feeding blower (0.55kW)	BM30055000250	BM30055000250	BM30055000250
7	Material outlet pipe	-	-	-
8	Material outlet pipe fixing flange	-	-	-
9	Stainless steel pipe clamp 4"	YW07000400000	YW07000400000	YW07000400000
10	Material outlet pipe bending	-	-	-
11	Filter cloth bag 2	BP82181800044	BP82181800044	BP82181800044
12	Cyclone separator	BY50002300150	BY50002300150	BY50002300150
13	Filter cloth bag 1	BP82321900144	BP82321900144	BP82321900144
14	Dust collecting cloth bag stand	BL59230001521	BL59230001521	BL59230001521

Please confirm the version of manual before placing the purchase order to guarantee that the item number of the spare part is in accordance with the real object.

15. Shield Parts (SG-23)

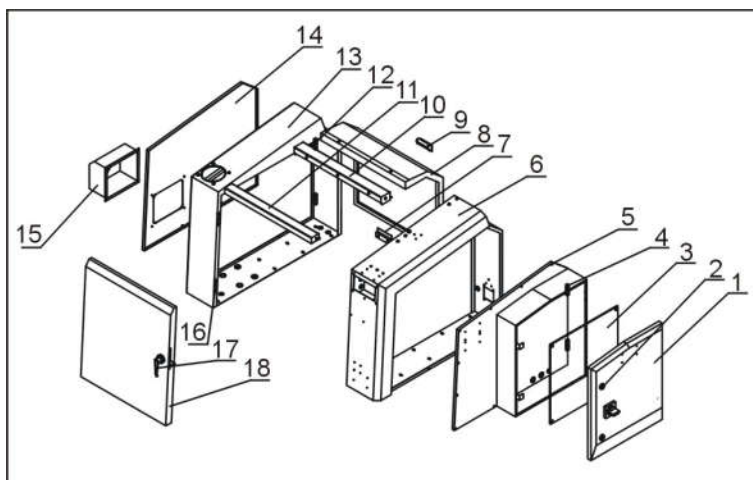

Note: Please refer to 16 material list about the parts code.

16. Parts List of Shield Parts (SG-23)

No.	Name	Part No.		
		SG-2324	SG-2336	SG-2348
1	Electric components box door plate	-	-	-
2	Long gear lock	YW00000000100	YW00000000100	YW00000000100
3	Wiring board	-	-	-
4	Big hinge CL203-1 (right)	YW06203100200	YW06203100200	YW06203100200
5	Electric components box base plate	-	-	-
6	Right outshell	-	-	-
7	Motor cover plate	-	-	-
8	Motor cover	-	-	-
9	Plastic ladder type handle 91*40	YR40914040000	YR40914040000	YR40914040000
10	Rear top cover	-	-	-
11	Front top cover	-	-	-
12	Big hinge CL203-1 (left)	YW06203100400	YW06203100400	YW06203100400
13	Left outshell	-	-	-
14	Left outshell cover	-	-	-
15	Blower motor cover shell	-	-	-
16	Hinge CL253-2	YW06253200000	YW06253200000	YW06253200000
17	Door lock M-45-B	YW00004500000	YW00004500000	YW00004500000
18	Front door	-	-	-

Please confirm the version of manual before placing the purchase order to guarantee that the item number of the spare part is in accordance with the real object.

1. Assembly Drawing(SG-30)

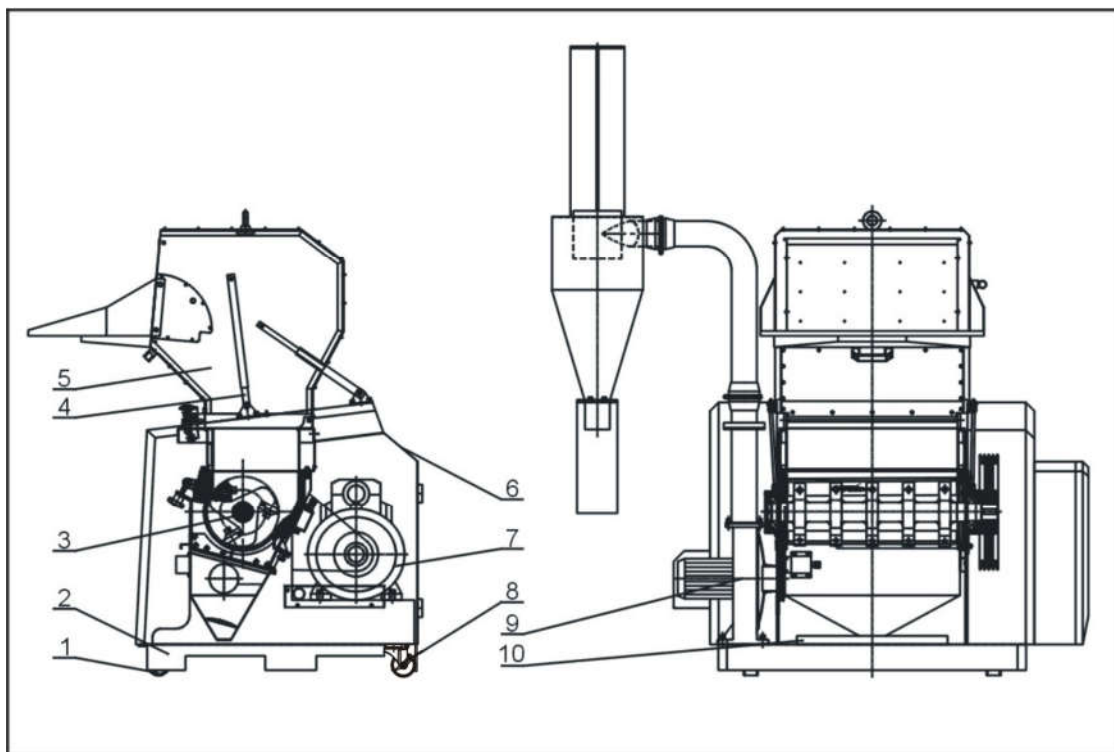

Note: Please refer to 2 material list about the parts code.

2. Parts List (SG-30)

No.	Name	Part No.	
		SG-3048	SG-3060
1	Fixed castor 3"	YW03000300500	YW03000300500
2	Machine rack	-	-
3	Cutting chamber	BH85304800810	BH85306000610
4	Elastic gasket 900N	YW01090000000	YW01090000000
5	Feed box	-	-
6	Shield parts	-	-
7	Main gear	-	-
8	Side brake of Movable castor 3"	YW03000300900	YW03000300900
9	Automatic feed	-	-
10	Presetting knife jig	BH11304800410	BH10300100110

Please confirm the version of manual before placing the purchase order to guarantee that the item number of the spare part is in accordance with the real object.

3. Main Gear(SG-30)

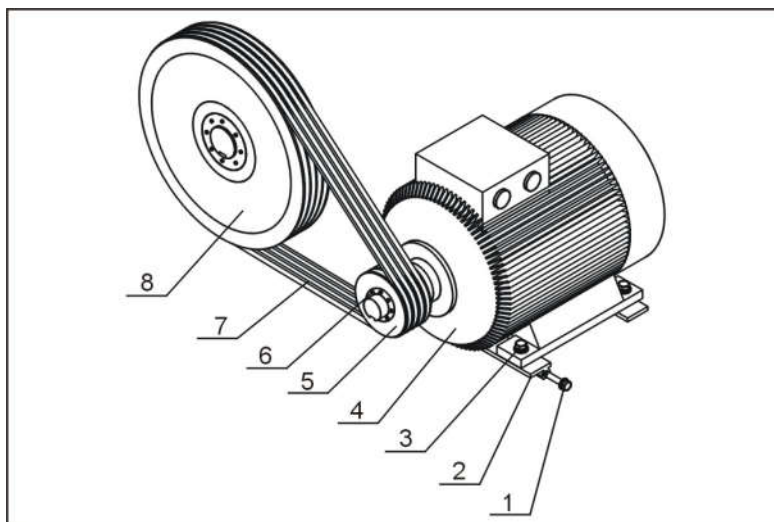

Note: Please refer to 4 material list about the parts code.

4. Parts List of Main Gear (SG-30)

No.	Name	Part No.	
		SG-3048	SG-3060
1	Hexagon head screw M10×80	YW60108000000	YW60108000000
2	Motor control board	BH10306500110	BH10306500110
3	Hexagon head screw M12×45	YW60124500000	YW60124500000
4	Motor	YM10716300300	YM10716600300
5	Motor belt pulley	BW30002305320	BW30002305320
6	Belt pulley taper sleeve	BW30003005320	BW30003005320
7	Triangle belt	YR00170040000	YR00170040000
8	Big wheel	BW30002305220	BW30002305220
9	Big wheel sleeve	BW30003005220	BW30003005220

Please confirm the version of manual before placing the purchase order to guarantee that the item number of the spare part is in accordance with the real object.

5. Cutting Chamber (SG-30)

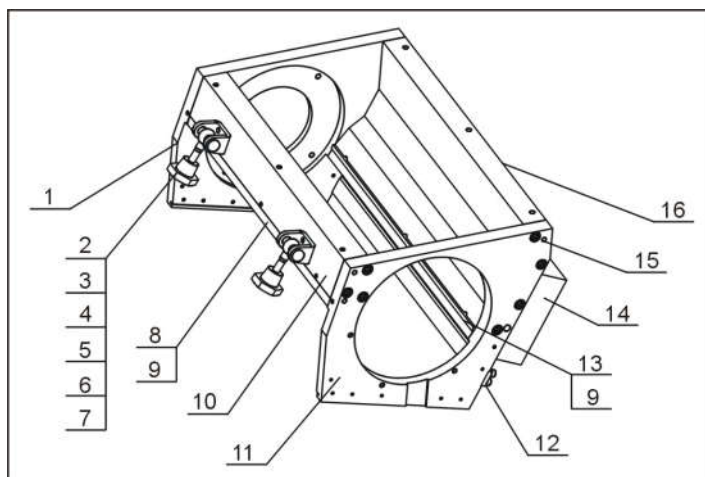

Note: Please refer to 6 material list about the parts code.

6. Parts List of Cutting Chamber (SG-30)

No.	Name	Part No.	
		SG-3048	SG-3060
1	Left side plate	BH10306501110	BH10306501110
2	Hinge base	-	-
3	Shaft pin	YW09301400000	YW09301400000
4	A type circlip for shaft 16	YW69001600000	YW69001600000
5	Star screw	YW09003010500	YW09003010500
6	Flat gasket	YW66123200100	YW66123200100
7	Star nut (M12)	YW09001200500	YW09001200500
8	Front pressing block	BW30304801310	BW30306101310
9	Fixed blades	YW42234800100	YW42325800000
10	Front block	BW30304800510	BW30306500010
11	Right side plate	BH10306101210	BH10306101210
12	Screen bracket fixing plate	-	-
13	Back pressing block	BW30304800910	BW30306901310
14	Water tank	-	-
15	Elastic fixing pin 8×40	YW69084000000	YW69084000000
16	Back block	BW30304800810	BW30306800310

Please confirm the version of manual before placing the purchase order to guarantee that the item number of the spare part is in accordance with the real object.

7. Cutting Chamber Two(SG-30)

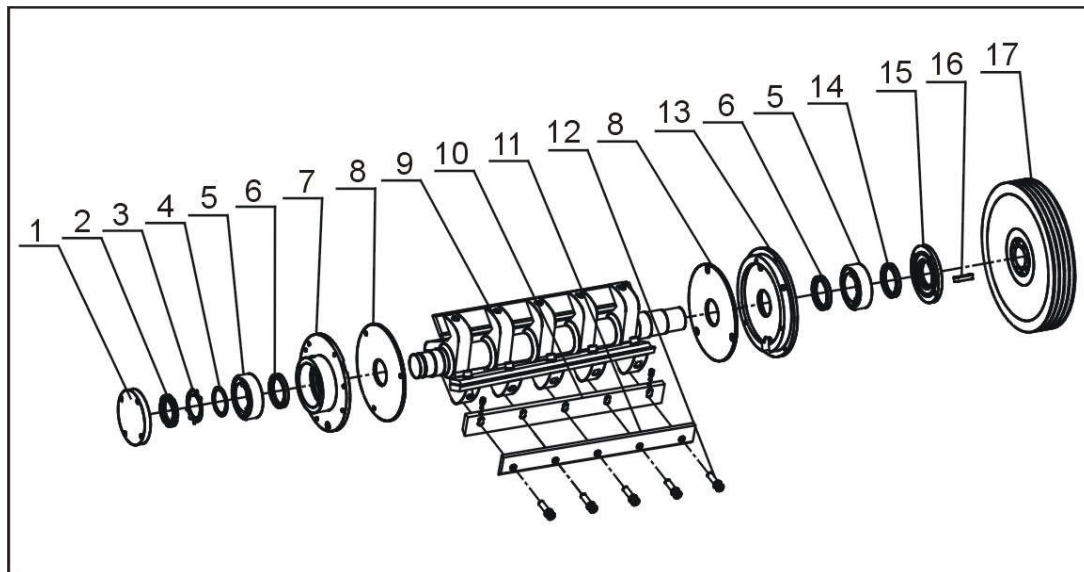

Note: Please refer to 8 material list about the parts code.

8. Parts List of Cutting Chamber Two (SG-30)

No.	Name	Part No.	
		SG-3048	SG-3060
1	Left bearing block cover plate	BW30301300010	BW30301300010
2	Round nut M64×2	YW64642000000	YW64642000000
3	Lock gasket 64	YW09640000000	YW09640000000
4	Bearing gasket	BL54301110020	BL54301110020
5	Self-aligning roller bearing 22213	YW11222100300	YW11222100300
6	Oil seal 90×70×10	YR80971000000	YR80971000000
7	Left bearing block	BW30301200010	BW30301200010
8	Material fender	BH11300820010	BH11300820010
9	Blade shaft	BH11306006110	BH11306006110
10	Rotary blades	BW42304800410	BW42306000710
11	Rotary blades pressing plate	BH11304803810	BH10306000910
12	Inner hexagon cylindrical screw	YW61145000000	YW61145000000
13	Right bearing block	BW30300202110	BW30300202110
14	Oil seal 80×65×8	YR80806500000	YR80806500000
15	Oil seal 80×65×8	YR80806500000	YR80806500000
16	Flat key 18×11×55	BH10301300310	BH10301300310
17	Big wheel	BW30002305220	BW30002305220
18	Big wheel sleeve	BW30003005220	BW30003005220

Please confirm the version of manual before placing the purchase order to guarantee that the item number of the spare part is in accordance with the real object.

9. Screen (SG-30)

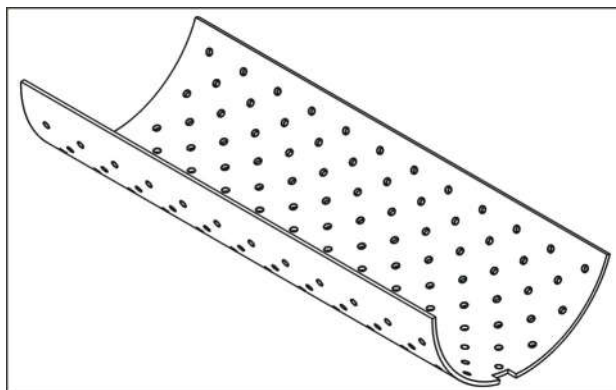

10. Parts List of Screen (SG-30)

No.	Name	Part No.	
		SG-3048	SG-3060
1	Screen 8mm	BL54304806020	BL54306006020

Please confirm the version of manual before placing the purchase order to guarantee that the item number of the spare part is in accordance with the real object.

11. Feed Box(SG-30)

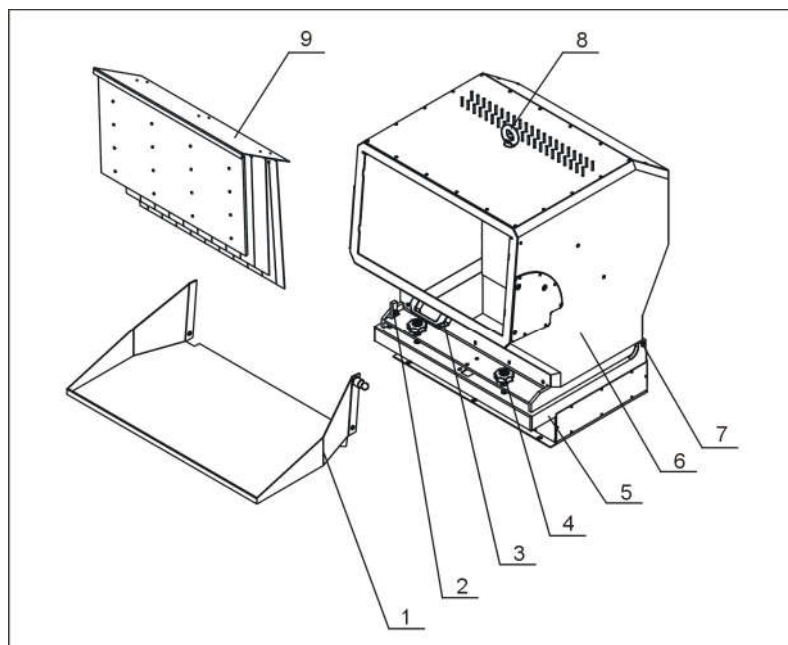

Note: Please refer to 12 material list about the parts code.

12. Parts List of Feed Box(SG-30)

No.	Name	Part No.	
		SG-3048	SG-3060
1	Feed port	-	-
2	Pothook	-	-
3	Aluminum square handle L120	BW20012000140	BW20012000140
4	Star screw combination	BH11300200010	BH11300200010
5	Cutting chamber	-	-
6	Feed box	-	-
7	Feed box shaft	BH10304801810	BH10306181310
8	Lifting screw M16	YW09001600000	YW09001600000
9	Material fender assembly	BR90304800020	BR90306000020

Please confirm the version of manual before placing the purchase order to guarantee that the item number of the spare part is in accordance with the real object.

13. Automatic Feeding Assembly (SG-30)

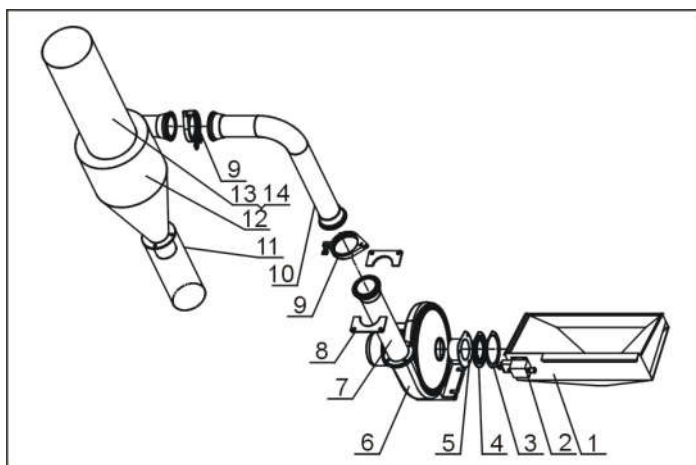

Note: Please refer to 14 material list about the parts code.

14. Parts List of Automatic Feeding Assembly (SG-30)

No.	Name	Part No.	
		SG-3048	SG-3060
1	Storage box	-	-
2	Spiral switch	-	-
3	Pressing plate	-	-
4	Material inlet fastener	YR10002300000	YR10002300000
5	Blower suction port connecting pipe	-	-
6	Feeding blower (0.55kW)	BM30055000250	BM30055000250
7	Material outlet pipe	-	-
8	Material outlet pipe fixing flange	-	-
9	Stainless steel pipe clamp 4"	YW07000400000	YW07000400000
10	Material outlet pipe bending	-	-
11	Filter cloth bag 2	BP82181800044	BP82181800044
12	Cyclone separator	BY50002300150	BY50002300150
13	Filter cloth bag 1	BP82321900144	BP82321900144
14	Dust collecting cloth bag stand	BL59230001521	BL59230001521

Please confirm the version of manual before placing the purchase order to guarantee that the item number of the spare part is in accordance with the real object.

15. Shield Parts (SG-30)

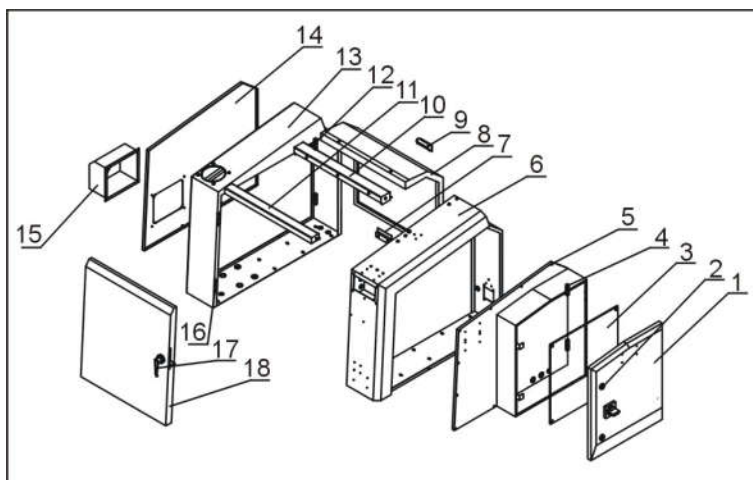

Note: Please refer to 16 material list about the parts code.

16. Parts List of Shield Parts (SG-30)

No.	Name	Part No.	
		SG-3048	SG-3060
1	Electric components box door plate	-	-
2	Long gear lock	YW00000000100	YW00000000100
3	Wiring board	-	-
4	Big hinge CL203-1 (right)	YW06203100200	YW06203100200
5	Electric components box base plate	-	-
6	Right outshell	-	-
7	Motor cover plate	-	-
8	Motor cover	-	-
9	Plastic ladder type handle 91×40	YR40914040000	YR40914040000
10	Rear top cover	-	-
11	Front top cover	-	-
12	Big hinge CL203-1(left)	YW06203100400	YW06203100400
13	Left outshell	-	-
14	Left outshell cover	-	-
15	Blower motor cover shell	-	-
16	Stainless steel hinge 3"	YW06000300000	YW06000300000
17	Door lock M-45-B	YW00004500000	YW00004500000
18	Front door	-	-

Please confirm the version of manual before placing the purchase order to guarantee that the item number of the spare part is in accordance with the real object.