

STM-PW

High Temp. Water Heater

Date:Jan. 2019

Version: Ver.H (English)



Contents

1. General Description	7
1.1 Coding Principle	8
1.2 Feature	8
1.3 Options	8
1.4 Technical Specifications	10
1.4.1 Specification	10
1.4.2 Reference Formula of Mould Controllers Model Selection	11
1.5 Safety Regulations	11
1.5.1 Safety Signs and Labels	11
1.5.2 Signs and Labels	12
1.5.3 Operation Regulations	13
1.5.4 Transportation and Storage of the Machine	14
1.6 Exemption Clause	16
2. Structure Characteristics and Working Principle	17
2.1 Working Principle	17
2.2 Options Installation	18
2.2.1 Installation steps for options water manifold (dewaxing)	18
2.2.2 Installation steps for options water manifold (welding)	19
3. Installation and Debugging	20
3.1 Installation Space	20
3.2 Mould and Water Coupling	20
3.3 Power Supply	21
4. Operation Guide	22
4.1 Control Panel	22
4.2 Menu Introduction	24
4.3 Menu Introduction	25
4.3.1 Main screen	25
4.3.2 MENU Screen	25
4.4 Parameter Table	26
4.4.1 Parameter Setting Table	26

4.4.2	Output Setting.....	29
4.4.3	Alarm Settings	30
4.4.4	Instrument Setting.....	31
4.4.5	SUCTION Function.....	31
4.4.6	Water Replenishment Function	31
4.4.7	Exhaust valve function.....	32
4.4.8	Plunger pump function.....	33
4.5	Errors and Causes	34
5.	Trouble-shooting	35
6.	Maintenance and Repair	37
6.1	Open the Covers.....	38
6.2	Y Type Strainer	39
6.3	Solenoid Valve	39
6.4	Pipe Heater	40
6.5	Maintenance Schedule.....	41
6.5.1	About the Machine.....	41
6.5.2	Installation & Inspection.....	41
6.5.3	Daily Checking.....	41
6.5.4	Weekly Checking	41
6.5.5	Trimonthly Checking.....	41
6.5.6	Half-yearly Checking.....	41
6.5.7	Yearly Checking.....	42
6.5.8	3 year Checking.....	42

Table Index

Table 1-1:	Specification	10
Table 3-1:	Cooling Water Demands.....	21
Table 4-1:	Key Function Specification	22
Table 4-2:	Main Screen	26
Table 4-3:	Control Setting.....	26
Table 4-4:	Alarm Setup.....	26
Table 4-5:	Output Setting.....	27

Table 4-6: Temp. Setting	27
Table 4-7: Time Setting	27
Table 4-8: One Week ON/OFF Setup.....	27
Table 4-9: Communication Setup	28
Table 4-10: Instrument Setup	28
Table 4-11: Refilling Setup	28

Picture Index

Picture 2-2: Working Principle	17
Picture 3-1: Installation Space	20
Picture 3-2: Mould and Water Couplings 1	20
Picture 3-3: Mould and Water Couplings 2	21
Picture 3-4: Mould and Water Couplings 3	21
Picture 4-1: Control Panel.....	22
Picture 4-2: Main Menu Screen	25
Picture 4-3: MENU Screen	25
Picture 6-1: Open the Covers 1	38
Picture 6-2: Open the Covers 2	38
Picture 6-3: Open the Covers 3	38
Picture 6-4: Y Type Strainer	39
Picture 6-5: Solenoid Valve	39
Picture 6-6: Pipe Heater 1	40
Picture 6-7: Pipe Heater 2	40
Picture 6-8: Pipe Heater 3	40

1. General Description



Read this manual carefully before operation to prevent damage of the machine or personal injuries.

STM-PW series high temp. water heaters are used to heat up the mould and maintain temperature, they can be used in other similar applications as well. High temp. water from mould through high-temp. heating pipe after it is pressurized by pump returns to the mould, which is cooled indirectly for heating and constant temperature purpose. With PID temperature control, it could ensure stable temperature control with accuracy reaching $180\pm 5^{\circ}\text{C}$.



Model: STM-607PW

1.1 Coding Principle

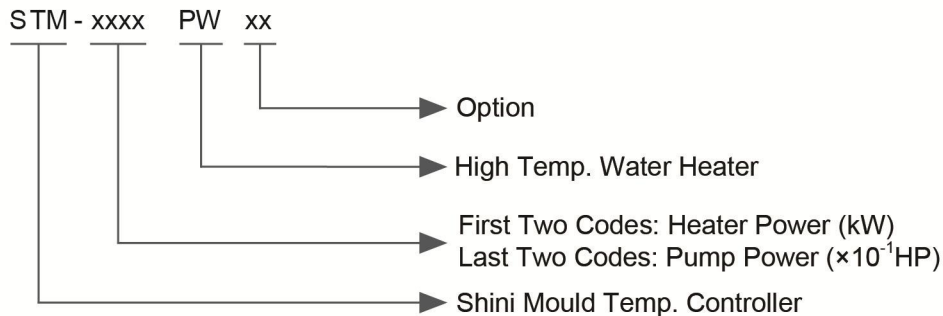

1.2 Feature

- P.I.D. multi-stage temperature control system can maintain an mould temperature with accuracy of $\pm 0.5^{\circ}\text{C}$.
- Adopts high efficiency water cycle magnetic pump, with which precise moulds and mould loop with minor diameter can achieve precise temperature control and high efficient heat exchange. Pump inside adopts stainless steel to avoid explosion.
- Multiple safety devices including power reverse phase protection, pump overload protection, overheat protection and low level protection that can automatically detect abnormal performance and indicate this via visible alarm.
- The highest temperature can reach 180°C .
- Equipped with high pressure protection, safety pressure relieving, automatic water supplying and air exhausting.
- Adopts indirect cooling, which makes temperature control more precise. The low viscosity of water realizes fast heat exchange.
- RS485 communication function is standard.
- Equipped with water level probe and high-pressure plunger pump .The water level probe can accurately detect the water level . When the system level is too low, the plunger pump to supply the high pressure system with water to avoid pipe dry burning.
- Standard equipped with buzzer.

1.3 Options

- Water manifolds and Teflon hose are optional.

- It could option with magnetic filter to prolong service life of magnetic pump. Add “MF” at the end of the model code.

All service work should be carried out by a person with technical training or corresponding professional experience. The manual contains instructions for both handling and servicing. Chapter 6, which contains service instructions intended for service engineers. Other chapters contain instructions for the daily operator.

Any modifications of the machine must be approved by SHINI in order to avoid personal injury and damage to machine. We shall not be liable for any damage caused by unauthorized change of the machine.

Our company provides excellent after-sales service. Should you have any problem during using the machine, please contact the company or the local vendor.

Headquarter and Taipei factory:

Tel: (886) 2 2680 9119

Shini Plastics Technologies (Dongguan), Inc:

Tel: (86) 769 8111 6600

Shini Plastics Technologies India Pvt.Ltd.:

Tel: (91) 250 3021 166

1.4 Technical Specifications

1.4.1 Specification

Table 1-1: Specification

Model	STM-607PW	STM-607PW-D	STM-1220PW	STM-1220PW-D	STM-2440PW
Ver.	H	E	H	B	C
Max. temp	180°C				
Heater (kW)	6	6×2	12	12×2	24
Pump (kw) (50/60Hz)	0.6	0.6×2	1.05	1.05×2	2.9
Max. pump flow (L/min) (50/60Hz)	25.5/28	25.5/28	50/60	50/60	100/120
Max. pump pressure (bar) (50/60Hz)	4.8/6.3	4.8/6.3	5.8/7.6	5.8/7.6	8/10.5
Heating tank number	1	2	1	2	2
Heating tank capacity	3.4	3.2×2	3.4	3.2×2	6.2
Cooling tank capacity	1.4	1.4×2	1.4	1.4×2	1.8
Coonling method	Indirect	Indirect	Indirect	Indirect	Indirect
Inlet / Outlet (inch)	3/4 / 3/4	3/4 / 3/4	3/4 / 3/4	3/4 / 3/4	1/1
Dimensions (mm) (H×W×D)	690×320×910	750×620×990	690×320×990	750×620×990	950×450×1050
Weight (kg)	80	185	90	190	140

Note: 1) "PW" stands for water medium with high temp.

- 2) To ensure stable water temperature, cooling water pressure should not be less than 2kgf/cm², but also no more than 5kgf/cm².
- 3) Pump testing standard: Power of 50/60Hz, purified water at 20°C.
(There is ±10% tolerance for either max. flowrate or max. pressure).
- 4) Power supply: 3Φ, 230/400/460/575VAC, 50/60Hz.

We reserve the right to change specifications without prior notice.

1.4.2 Reference Formula of Mould Controllers Model Selection

Heater Power (kW) = mould weight (kg) × mould specific heat (kcal/kg°C) × temperature difference between mould and environment (°C) × safety coefficient / heating duration / 860

Note: safety coefficient can select a value from 1.3 to 1.5.

Flow Rate (L/min) = heater power (kw) × 860 / [heating medium specific (kcal/kg°C) × heating medium density (kg/L) × in/outlet temperature difference (°C) × time (60)]

Note: Water specific heat = 1kcal/kg°C

Heating medium oil specific heat = 0.49kcal/kg°C

Water density = 1kg/L

Heating medium oil density = 0.842kg/L

1.5 Safety Regulations

Strictly abide by the following safety regulations to prevent damage of the machine or personal injuries.

1.5.1 Safety Signs and Labels



Danger!

The unit is designed to endure high temp, and high pressure. For safe operation, do not remove the covers or switches.



Attention!

The unit should be operated by qualified personnel only.

During operation, avoid wearing gloves or clothes that may cause danger.

Turn off main switch when power supply is off.

Stop the unit when there may be power supply problems caused by static electricity.

Put on safety gloves and shoes during installation or relocation.

Components from our company can only be used for replacement.



Warning!

Do not touch the switch with wet object or hands.

Do not use the machine before fully aware of its performance.
 Be careful not to touch or hit the switch or sensor.
 Please keep enough operation space, and keep away obstacles.
 To avoid producing statics, clean the floor from oil or water to keep a dry environment.
 Protect the machine against severe vibration or collision.
 Do not remove safety signs or make it dirty.
 Drunken, medicine-taking, or men without proper judgement should not operate the machine.



Warning!

High temperature, take care of hands! This label is attached on the surface of heating parts.

1.5.2 Signs and Labels

	<p>From mould: connector for circulating water/oil coming from mould.</p>
	<p>Pump pressure meter: indicating actual pressure of system.</p>
	<p>To mold: connector for circulating water/ oil to go to mould.</p>
	<ol style="list-style-type: none"> To maintain temperature consistency, cooling water pressure must be higher than 2 bar at all time, but should never exceed 5 bar in any case. Clean Y-shape Cooling Water Strainer periodically to ensure perfect cooling capacity.

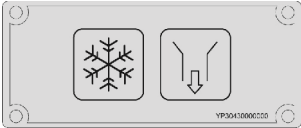
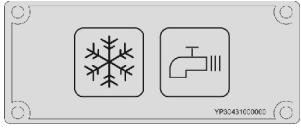
	Water outlet: drainage outlet.
	Water inlet: inlet for replenishing water and cooling water.

Please abide by the safety guide when you operate the machine so as to prevent damage of the machine and personal injuries.



All electrical components should be installed by qualified electricians. Turn off main switch and control switch during repair and maintenance.



Warning! High voltage!

This mark is attached on the cover of the control box.



Warning! Be careful!

Be more careful when this mark appears.

1.5.3 Operation Regulations

- 1) Before operation, make sure that cooling water is clean soft water without pollutants.
 - ※ Low quality water brings limescales, which may cause problems.
- 2) If problems of drainage or bad temperature control are noted, please clean solenoid valve and cooling water inlet and outlet.
- 3) Do not move the unit when it is in operation.
- 4) When in need of repairing, wait until oil temperature falls below 30°C.
- 5) Motor overload may be caused by phase shortage, pipe obstruction, broken bearing, etc. Motor overload relay will trip off to stop the machine when this happens. Fixing the problems, press RESET on overload relay to clear the alarm.
- 6) Before turn off the pump, wait until oil temperature falls below 50°C. Or the life of the unit would be affected.

- 7) If the setting temperature is below 100°C, then the pressure switch setting value should be 1.5-2 bar; If the setting temperature sets between 100°C and 200°C, then the recommendable pressure switch setting value should be 2.8 bar. If the cooling water pressure is too low, then the pressure switch setting value can be adjusted properly to ensure normal running. However, it may affect the limitation of setting temperature or cause unstable temperature control.
- 8) Please connect the cooling water outlet with high temperature resistant pipe when temperature is above 100°C.

1.5.4 Transportation and Storage of the Machine

Transportation

- 1) STM-PW series standard oil heaters are packed in crates or plywood cases with wooden pallet at the bottom, suitable for quick positioning by fork lift.
- 2) After unpacked, castors equipped on the machine can be used for ease of movement.
- 3) Do not rotate the machine and avoid collision with other objects during transportation to prevent improper functioning.
- 4) The structure of the machine is well-balanced, although it should also be handled with care when lifting the machine for fear of falling down.
- 5) The machine and its attached parts can be kept at a temperature from -25°C to +55°C for long distance transportation and for a short distance, it can be transported with temperature under +70°C.

Storage

- 1) STM-PW series standard oil heater should be stored indoors with temperature kept from 5°C to 40°C and humidity below 80%.
- 2) Disconnect all power supply and turn off main switch and control switch.
- 3) Keep the whole machine, especially the electrical components away from water to avoid potential troubles caused by the water.
- 4) Plastic film should be used to protect the machine from dust and rains.

Working environment

The machine should be operated:

- 1) Indoors in a dry environment with maximum temperature +45°C and humidity not more than 80%.

Do not use the machine:

- 1) If it is with a damaged cord.
- 2) On a wet floor or when it is exposed to rain to avoid electrical shock.
- 3) If it has been dropped or damaged until it is checked or fixed by a qualified serviceman.
- 4) This equipment works normally in the environment with altitude within 3000m.
- 5) At least a clearance of 1m surrounding the equipment is required during operation. Keep this equipment away from flammable sources at least two meters.
- 6) Avoid vibration, magnetic disturbance at the operation area.

Rejected parts disposal

When the equipment has run out its life time and can not be used any more, unplug the power supply and dispose of it properly according to local code.

Fire Hazard



In case of fire, CO₂ dry powder fire extinguisher should be applied.

Please abide by the safety guide when you operate the machine so as to prevent damage of the machine and personal injuries.



All electrical components should be installed by qualified electricians.

Turn off main switch and control switch during repair and maintenance.



Warning! High voltage!

This mark is attached on the cover of the control box.



Warning! Be careful!

Be more careful when this mark appears.



Warning!

High temperature, take care of hands! This label is attached on the surface of heating parts.

1.6 Exemption Clause

The following statements clarify the responsibilities and regulations born by any buyer or user who purchases products and accessories from Shini (including employees and agents).

Shini is exempted from liability for any costs, fees, claims and losses caused by reasons below:

1. Any careless or man-made installations, operation and maintenances upon machines without referring to the Manual prior to machine using.
2. Any incidents beyond human reasonable controls, which include man-made vicious or deliberate damages or abnormal power, and machine faults caused by irresistible natural disasters including fire, flood, storm and earthquake.
3. Any operational actions that are not authorized by Shini upon machine, including adding or replacing accessories, dismantling, delivering or repairing.
4. Employing consumables or oil media that are not appointed by Shini.

2. Structure Characteristics and Working Principle

2.1 Working Principle

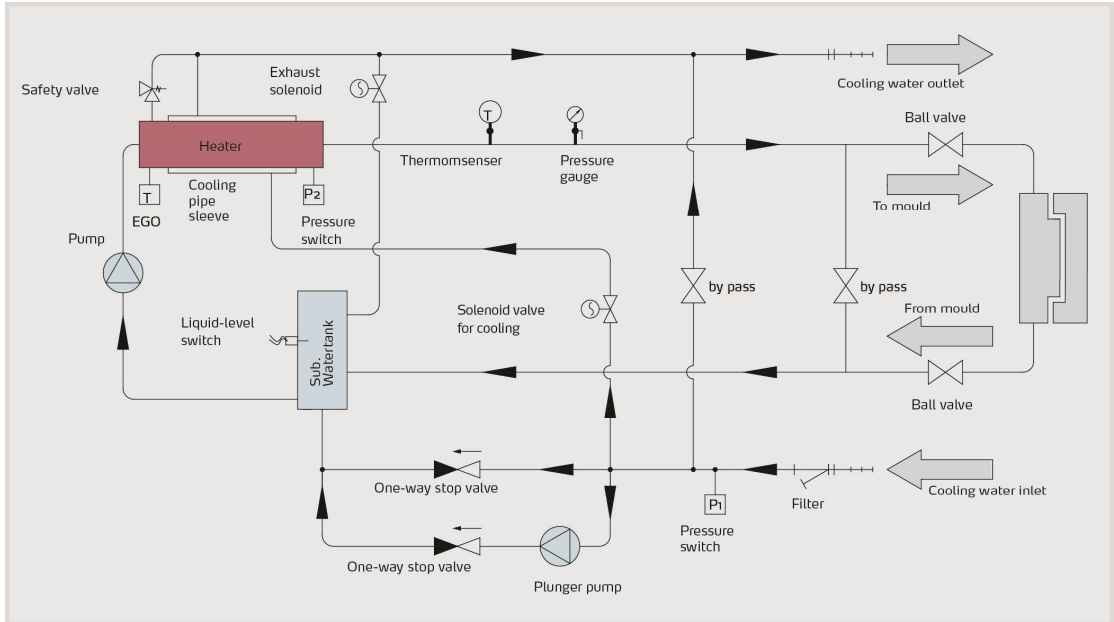

Picture 2-1: Working Principle

High-temp. water from the mold turns back to pump inlet through the pipeline and is sent to the heater by pump pressurizing, then it gets into the mold after heating by pipe heater, and so on. During the process, if probe detects the water level drops to the set value, the machine will start plunger pump to refill the water for 30 secs., and it will shut down to alarm if the water is still at low level. If the high-temp. water is too high, the system will start the cooling solenoid valve, and the cooling water will enter the double-tube structure to cool down the high temp. water, so that it can maintain constant water temperature. If the water temp. is still high and gets to the set EGO temperature, the system will sound alarm and stop. When system pressure is higher than the high-voltage switch set value, the machine will automatically release the pressure. If the pressure continues to rise to the safety valve set value, the mechanical safety valve opens to release the pressure of the system.

2.2 Options Installation

2.2.1 Installation steps for options water manifold (dewaxing)

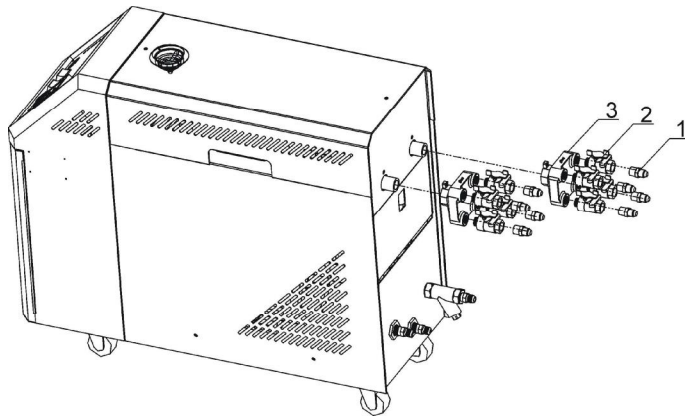

- 1) Install copper joint to the level valve.
- 2) Install level valve with copper joint to the dewaxing water manifold.
- 3) Install water manifold to the machine.
- 4) Install Teflon to copper joint.

Note: For the operating temperature not higher than 200 °C, Teflon with temperature resistance 200 °C is usable; for the operating temperature from 200 to 300 °C, must use Teflon with temperature resistance 300 °C.

2.2.2 Installation steps for options water manifold (welding)

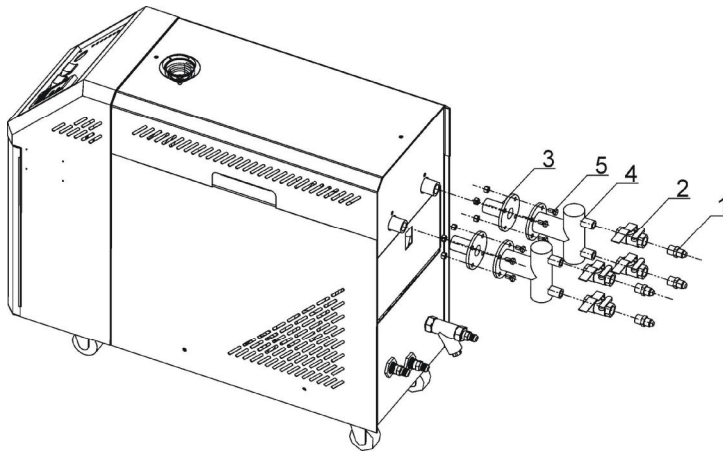

- 1) Install copper joint to the level valve.
- 2) Install level valve with copper joint to the welding water manifold.
- 3) Install water manifold to the machine.
- 4) Connect water manifold with manifold joint via screws.
- 5) Install Teflon to copper joint.

Note: For the operating temperature not higher than 200 °C, Teflon with temperature resistance 200 °C is usable; for the operating temperature from 200 to 300 °C, must use Teflon with temperature resistance 300 °C.

3. Installation and Debugging

3.1 Installation Space

During installation of the machine, keep at least 500mm installation space around the machine as shown by the picture. Do not install the machine in a position crowded with other objects. This would cause inconvenience to operation, maintenance and repair.

Do not sit on the machine.

Keep away flammable and explosive goods.



Picture 3-1: Installation Space

3.2 Mould and Water Coupling

- 1) It is necessary, while connecting from the access to mould, to use two spanners to fix the switching connection and ball valve before screw tightly the horn nut of the connection pipe, otherwise water might leaks from the machine.

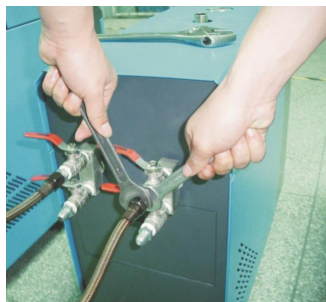

Picture 3-2: Mould and Water Couplings 1

- 2) Unused mould couplings can be connected with each other by a teflon pipe, as shown in.



Picture 3-3: Mould and Water Couplings 2

- 3) Connect cooling water inlet with water supply and cooling water outlet with a drainage pipe. After that, turn on water supply.

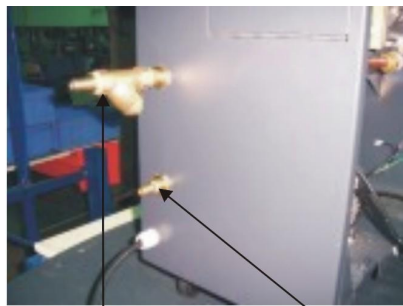

Cooling water outlet Cooling wate inlet

Picture 3-4: Mould and Water Couplings 3

Note: Cooling water inlet and outlet as shown by the Figure. Please do not connect reversely. Please connect the cooling water outlet with high temperature resistant pipe when temperature is above 100°C.

Table 3-1: Cooling Water Demands

Common demands of the cooling water			
Pressure	Flow	Temp.	Water Qua.
2bar<5bar	>2m ³ /h	Mormal Temp. water	Refer to the Water Quality for Industrial Boilers GBT 1576-2008

3.3 Power Supply

Make sure that power supply is the same as required before installation.
Specific power specifications please refer to the circuit diagram of each model.

4. Operation Guide

4.1 Control Panel

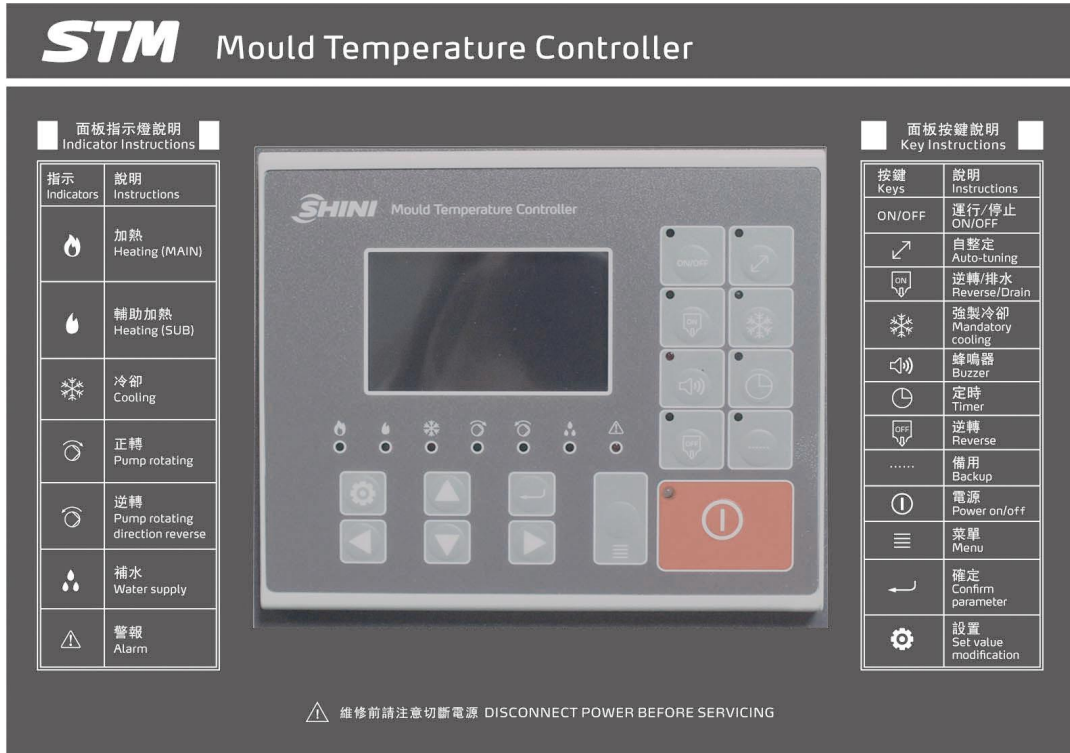

Picture 4-1: Control Panel

Table 4-1: Key Function Specification

No.	Name	Functions	Remarks
1	Heating(Main)	Heating output indicator	-
2	Heating(SUB)	Auxiliary heating output indicator	-
3	Cooling	Forced cooling button	Hold the button for 2 secs to enable force cooling. It stop heating while enable 100% cooling. It stops after the temperutre drops below Cooling Temp.
4	Pump rotating	Display pump direct running indicator	
5	Pump rotating direction reverse	Pump reverse running indicator	
6	Water supply	Water refill indicator	
7	Alarm	Alarm indicator	Refer to 4.5 for errors instruction.

No.	Name	Functions	Remarks
8	ON/OFF POWER	Run/stop power key	
9	Auto-tuning	Auto-tuning	
10	Reverse/Drain	Reverse/drain	
11	Mandatory cooling	Mandatory cooling	
12	Buzzer	Buzzer off switch	After press "BUZZER" button, "BUZZER" LED on, Buzzer and alarm relay in idle mode even error occurs.
13	Timer	Timer	
14	Reverse	Reverse key	
15	Backup	Backup	
16	Power ON/OFF	Confirmation key	
17	Confirm parameter	Ebter key	
18	SET	SET key	Confirm the parameter value

4.2 Menu Introduction

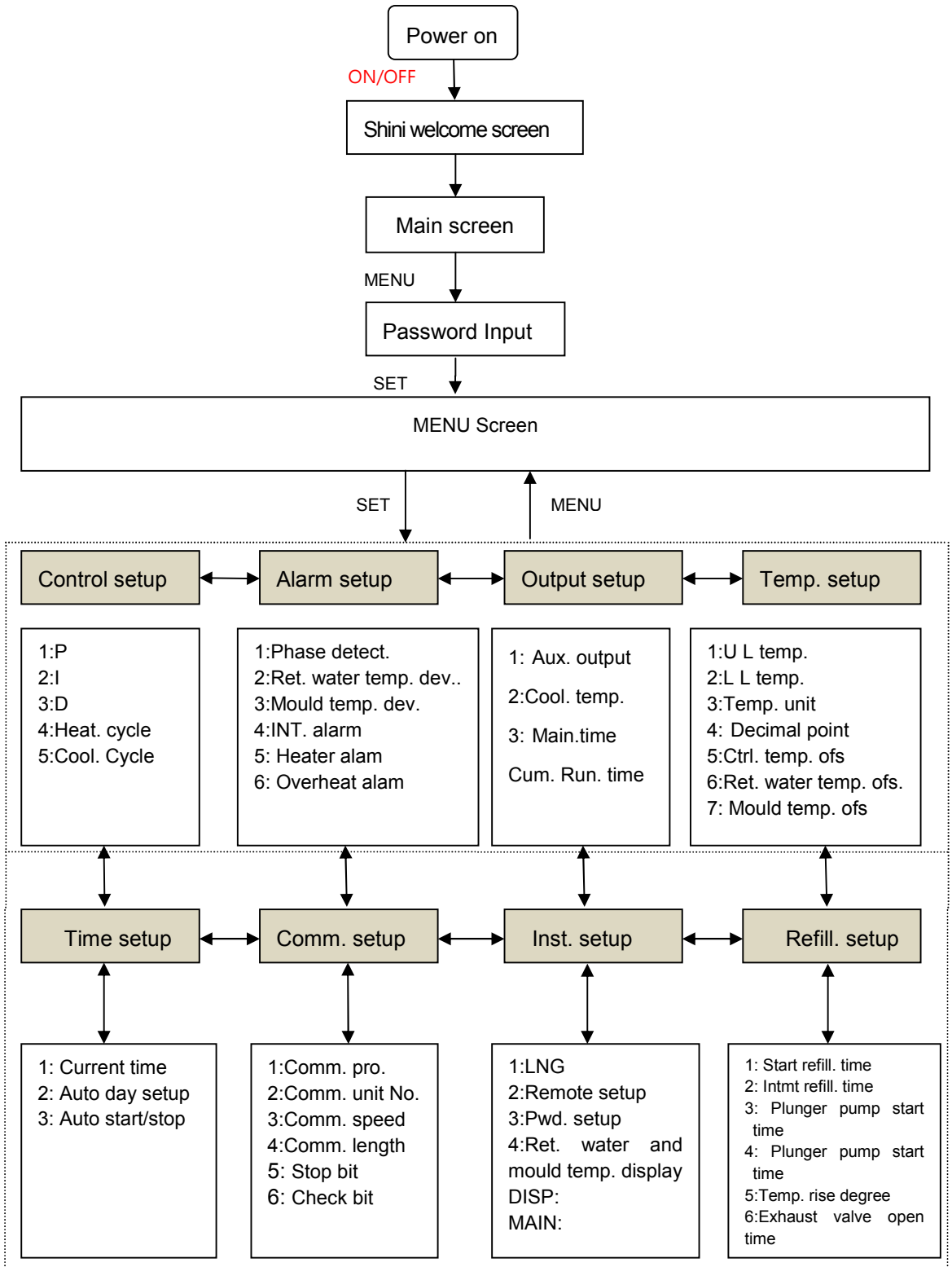

4.3 Menu Introduction

4.3.1 Main screen

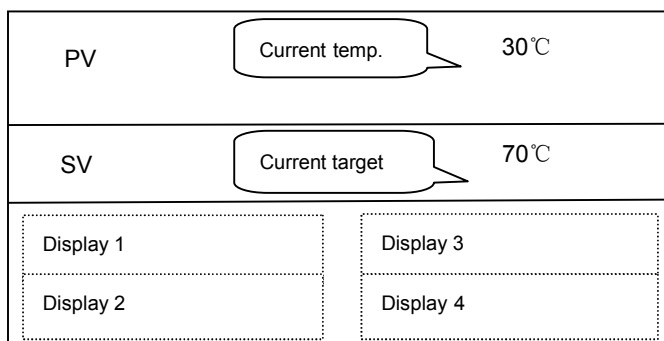

Picture 4-2: Main Menu Screen

Display	Function
Display 1	Display system time
Display 2	Reserved time (reserve startup) / output percentage (start temp.control)
Display 3	System state / return water temp.(Return water and mould temp. display power consumption, and press SET key on the main screen, it displays the temp. of return water).
Display 4	System state/mould temp. (Return water and mould temp. display power consumption, and press SET key on the main screen, it displays mould temp.)

Notes: The SV value range varies from different models.

4.3.2 MENU Screen

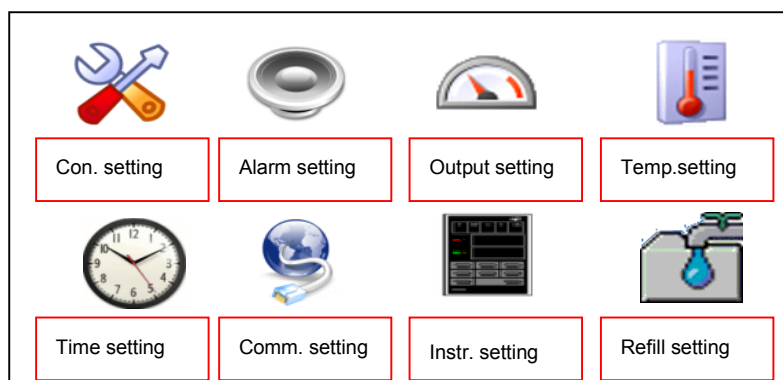

Picture 4-3: MENU Screen

1. Press <Shift> button to select different function menus, and enter the function menu by pressing the <Set> button.

2. In the function menu, select different parameters by pressing <up> or <down> button.

4.4 Parameter Table

4.4.1 Parameter Setting Table

Table 4-2: Main Screen

Parameter	Description	Range	Default
SV	Control temp.	0-350°C (32°F -662°F)	180°C

Table 4-3: Control Setting

Parameter	Description	Range	Default
P	Proportional band	1-100°C (2-212°F)	15°C (59°F)
I	Heating integral time	1-999S	85S
D	Heating to differential time	1-999S	5S
Heating cycle	Heating output cycle (SSR Heating cycle = Heating cycle/10)	3-60S	15S
Cooling cycle	Cooling output cycle	1-30S	15S

Table 4-4: Alarm Setup

Parameter	Description	Range	Default
Phase detection	for three-phase detection	use/not use	use
Ret. water temp. dev.	Control temp. and return water temp. deviation alarm	0-100°C (0= not use)	0
Mould temp. dev.	Control temp. and mould temp. deviation alarm	0-100°C (0= not use)	0
Disruption alarm	Temp. sudden drop alarm	0-300°C (0= not use)	0
Heater alarm	It doesn't reach set temp. in required time	0-3600S	0
Over temp. alarm	PV>SV+overheat alarm set temp., it alarms and stops	0-50°C	20°C

Table 4-5: Output Setting

Parameter	Description	Range	Default
Auxiliary output	Auxiliary output OFF temp.	0-300°C (0= not use)	1°C
Cooling temp.	Forced cooling temp.	0-100°C (0= not use)	35°C
Overhaul temp.	Set machine running time before maintenance	0-10000H (0= not use)	0
Total running time	Total machine running time		

Table 4-6: Temp. Setting

Parameter	Description	Range	Default
Temp. upper limit	SV upper limit temp. can be set	0-350°C	180°C
Temp. lower limit	SV upper lower temp. can be set	0-350°C	0°C
Temp. unit	°C/°F setting	°C、°F	°C
Decimal point	Temp.value of decimal point can be set	0.1、1	1
Control temp. offset	Control temp. offset	-100-100°C	0°C
Return water temp. offset	Return water temp. offset	-100-100°C	0°C
Mould temp. offset	Mould temp. offset	-100-100°C	0°C

Table 4-7: Time Setting

Parameter	Description	Range	Default
Current time	Current time setting	hr./min./week	No
Reserve the week	Reserve power ON/OFF	ON/OFF	OFF

Table 4-8: One Week ON/OFF Setup

Parameter	Description	Range	Default (start/stop)
Mon.	Reserved ON/OFF time on Mon.	hr/min., hr/min.	00:00, 00:00
Tues.	Reserved ON/OFF time on Tue.	hr/min., hr/min.	00:00, 00:00
Wed.	Reserved ON/OFF time on Wed.	hr/min., hr/min.	00:00, 00:00
Thu.	Reserved ON/OFF time on Thu.	hr/min., hr/min.	00:00, 00:00
Fri.	Reserved ON/OFF time on Fri.	hr/min., hr/min.	00:00, 00:00
Sat.	Reserved ON/OFF time on Sat.	hr/min., hr/min.	00:00, 00:00
Sun.	Reserved ON/OFF time on Sun.	hr/min., hr/min.	00:00, 00:00

Table 4-9: Communication Setup

Parameter	Description	Range	Default
Comm. protocol	Comm. protocol	Modbus-RTU	Modbus-RTU
Comm. unit No.	Comm. address	1-99	1
Comm. speed	Comm. speed	4800、9600、19200	19200
Comm. length	Data length	7, 8Bit	8Bit
Stop bit	stop bit	1, 2Bit	1Bit
Check bit	check bit	-,odd,even	-

Table 4-10: Instrument Setup

Parameter	Description	Range	Default
Language	language selection	Chinese/English	Chinese
Far-end setting	far-end setting	use/not use	not use
Password setting	password setting	0-9999	0
Return water and mould temp. display	Return water and mould temp. display	use/not use	not use
DISP	TFT version		
MAIN	control board version		

Table 4-11: Refilling Setup

Parameter	Description	Range	Default
Startup refill time	startup refill time	0-601S	180
Intermittent refill time	intermittent refill time	0-600S	20
Plunger pump start time	Plunger pump start time	0-180S	60
Plunger pump stop time	Plunger pump stop time	0-180S	60
Temp. rise degree	Temp. rise degree	0-100℃	5
Exhaust valve open time	Exhaust valve open time	0-990S	0.2
Low level alarm time	Low level alarm time	0-600S	180

4.4.2 Output Setting

1. Main output and auxiliary output of heating control

- 1) When control temp. is smaller than set value, initiate main output and auxiliary output to promptly improve the temp.
- 2) Alternatively select the main output and auxiliary output.

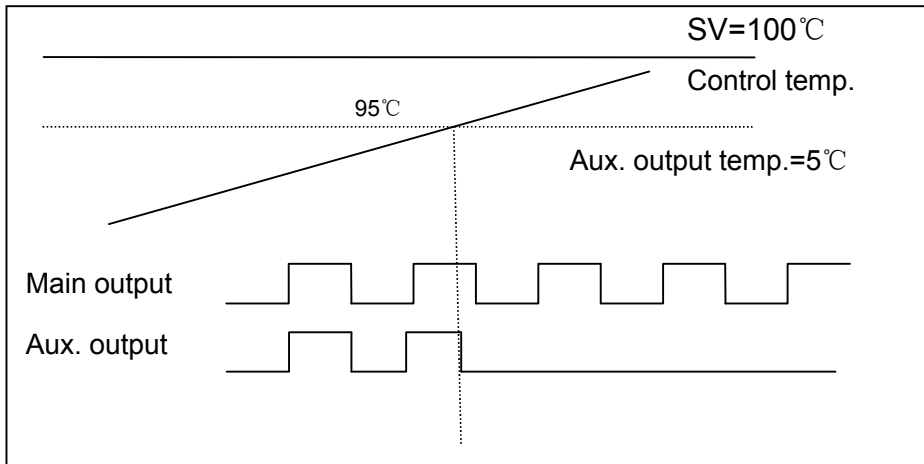

2. Forced cooling

- 1) Press the forced cooling key to stop heating and 100% output the cooling control.
- 2) Control temp. is lower than the cooling temp., automatically dismiss the forced cooling to terminate the control.
- 3) Forced cooling key is available to stop forced cooling for normal control.

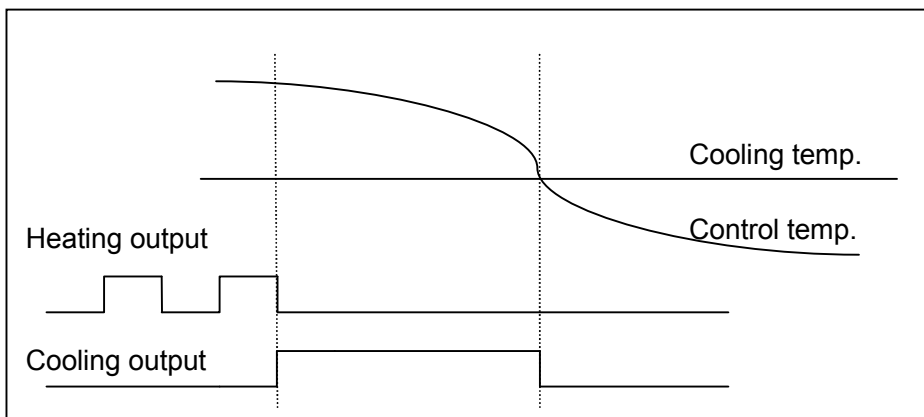

4.4.3 Alarm Settings

1. Phase shortage and reverse alarm

- 1) The alarm will sound when the phase can't be detected or R, S, T wrong connection, and the control will stop.

2. Water output temp. deviation and mould temp. deviation alarm

- 2) If the difference of control temp. and water output temp. is larger than the set value, the alarm will sound.
- 3) If the difference of control temp. and mould temp. is larger than the set value, the alarm will sound.
- 4) The two alarms only work during the controls, and the control works normally when alarm sounds.

3. Interference Alarms

- 1) If the control temp. is kept more than 1 sec. of the set interference alarm temp., it is considered as interference to sound the alarm.
- 2) The interference alarm only works during the controls with cooling output.
- 3) Once it sounds the alarm, the alarm will last till it presses BUZZER button to cancel the alarm.

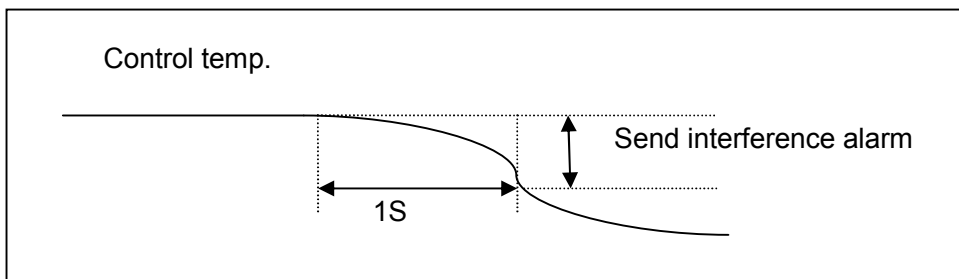

4. Heater Alarm

- 1) In heater alarm setting time, it will alarm when the control temp. can't reach 5°C below the set temp.
- 2) The heater alarm only works in controls, and once it reaches the temp. range, the alarm will be dismissed.
- 3) Even it sounds the alarm, the temp. control is still effective.

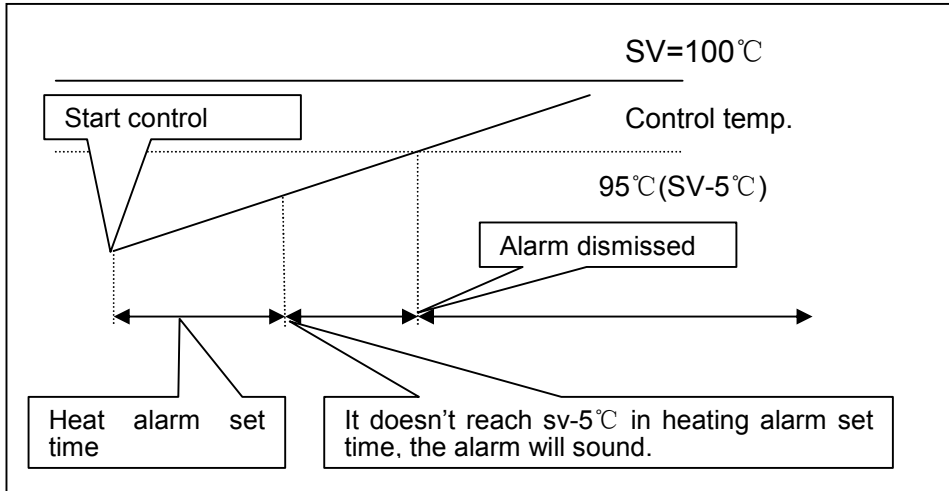

4.4.4 Instrument Setting

Parameters	Meaning
Language selection	English/Chinese
Remote temp. setting	The external voltage (1-5VDC) signal can be used to set the control temp. E.g: Upper limit temp. =300°C, Lower limit temp. =100°C, 1V input corresponds to 100°C, 5V corresponds to 300°C.
Password setting	The password is set same as the number entering the MENU.

4.4.5 SUCTION Function

1. SUCTION removes the medium (water or oil) in the mould
2. Unable to start during the operation or cooling.
3. After the SUCTION is activated, "SUCTION relay" and "pump reverse relay" work simultaneously.
4. Press the SUCTION OFF key in the SUNCTION functions, the "SUCTION relay" will stop but the "pump reverse relay" still works.
5. The SUCTION OFF button is only available in SUNCTION actions.

4.4.6 Water Replenishment Function

1. Use the replenishing functions of the contact input terminals
 - 1) The water detection level will start once it presses the ON/OFF button, which is irrelevant to the running state.

- 2) Low level contact input signal, and the replenishment relay immediately starts the refilling.

2. Startup replenishment

- 1) When the startup time is set as 601s, the water level will be replenished to the high level, it then starts PID operation.
- 2) When the startup replenishment <601S, the PID will operate after water replenishment processed according to the set time.

3. Low level alarm

- 1) The alarm will send out 3S after the detection of low level input signal.
- 2) Machine stops.
- 3) Once it alarms, the alarm will last till presses the BUZZER button to cancel the alarm.

4. Intermittent Replenishment

Presss RUN key to refill the water.

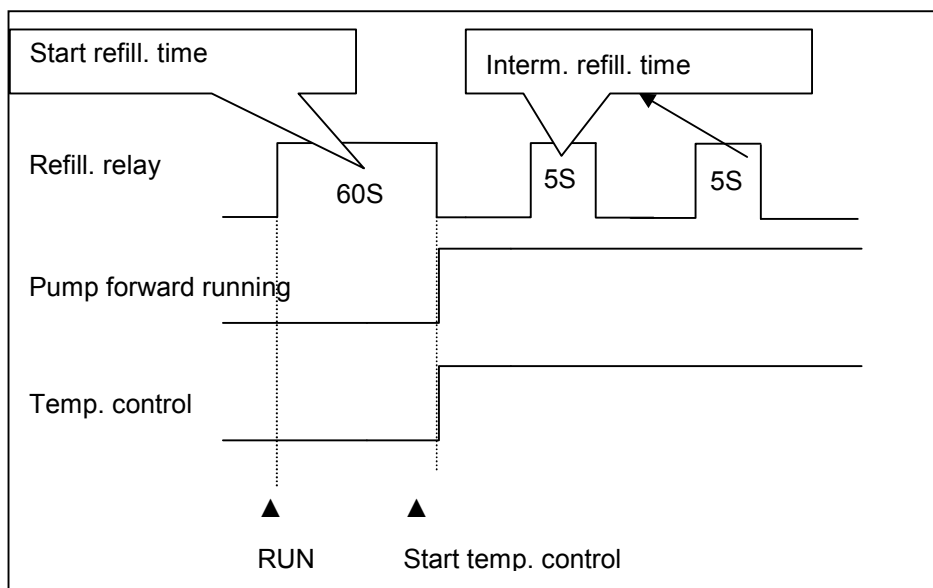

4.4.7 Exhaust valve function

1. The exhaust valve should be open when the machine starts (RUN) till the replenishment ends, and the machine will start once it detects the high level signal after refilling. If there's no high level signal, it alarms for the low level.

2. When machine enters the running state, after the actual temperature rises to a constant value (can be set), the exhaust valve will open for some time (can be set) to be used for the limitation system pressure and ensure normal operation.
3. The exhaust valve opens according to the set time, when the high pressure signal lasts 5s, it is still at the high pressure state, the high pressure alarm will sound.

4.4.8 Plunger pump function

1. If no high level input signal is detected after heating for a period of time, open the plunger pump according to the set parameter (plunger pump start time), and close the plunger pump according to the set parameter (plunger pump close time) till it detects the high level input signal.
2. When there's no high level input signal detected, start timing according to the parameter (low level alarm time). If the time exceeds the set time, it sounds low level alarm.

4.5 Errors and Causes

Errors	Causes	Alarm	Temp. control
Phase alarm	phase shortage or phase reverse detected	occur	stop
EGO	EGO contact input detected	occur	stop
Pump overload	pump overload contact input detected	occur	stop
High pressure input	high pressure contact input	occur	stop
Low pressure input	low pressure contact input	occur	stop
Low water (liquid) level	low water (liquid) level contact input detected	occur	stop
PV"----" display	K-TYPE line break	occur	stop
Overheat alarm	Control temp. exceeds set temp. + protection temp.	occur	stop
Return water temp. deviation	Control temp. and return water temp. deviation	occur	state maintain
Mould temp. deviation	Control temp. and mould temp. deviation	occur	state maintain
Disruption alarm	Control temp. sudden drop	occur	state maintain
Heater alarm	Control temp. doesn't rise	occur	state maintain

Notice:

As various alarms above, the controller will activate the protective function as auto shutdown or stop running; please re-press the "operation" to restart.

5. Trouble-shooting

Failures	Possible reasons	Solutions
LCD displays nothing after switch on power and press ON/OFF key.	Did not connect through power supply. Main switch broken. Power supply wires problems. Control circuit fuse melt. Transformer broken.	Connect through power supply. Replace main switch. Check electrical wires. Fix the fuse. Replace the transformer.
Phase alarm.	Power supply low voltage. Phase shortage. Phase reversal. PCB problems.	Check power supply. Check power supply. Exchange two of the wires of power supply. Replace the PCB.
Pump overload.	Abnormal fluctuations of power supply. Pump blocked. Pump motor problems. Overload relay (F1) setting value error.	Check power supply. Check the pump. Check pump motor. Set the setting current of overload relay to equal to 1.1 times of motor rated current. Please refer to Mian Components for detailed description of overload relay. Reset overload relay: Wait for one minute, then press the blue button to reset.
EGO overheat.	EGO temperature setting mistakes. EGO poor temperature detecting. Heater contactor K1 and K2 problems.	Correctly set EGO temperature. (EGO temperature setting value= temperature setting value+10℃) Replace EGO. Replace the contactor.
Low liquid level.	Oil shortage.0	Fill high temp. oil.
Temp. window displays "----"	Abnormal sensor.	Check and repair sensor.
Once running, pump output indicator lightens but pump cannot start. Afetr a while pump still fails to run.	PCB output relay problems. Electrical circuit problems.	Check or replace the PCB. Check electrical circuit.
Differences between setting temperature and actual temperature is too big.	Too short time after machine startup. Temperature parameter setting error. Cooling water valve problems.	Wait for a while. Check temperature parameters. Please refer to the standard manual of setting parameters. Replace solenoid valve.
Temperature can't rise up.	Heater contactor problems. Heater problems. Thermocouple problems. PCB output point problems.	Replace the contactor. Replace pipe heater. Replace thermocouple. Check and repair PCB.

Failures	Possible reasons	Solutions
Circuit breaker tripping off at turning on main switch.	Short circuit of main circuit. Transformer short circuit or connected with earth wire. Problems of circuit breaker.	Check electrical wire. Replace circuit breaker.
Circuit breaker tripping off at turning on pump switch.	Pump motor coil short circuit. Problems of circuit breaker.	Check pump motor. Replace circuit breaker.
Circuit breaker tripping off after short heater output.	Heater tube short circuit or shell contact. Problems of circuit breaker.	Replace heater tube. Replace circuit breaker.

6. Maintenance and Repair

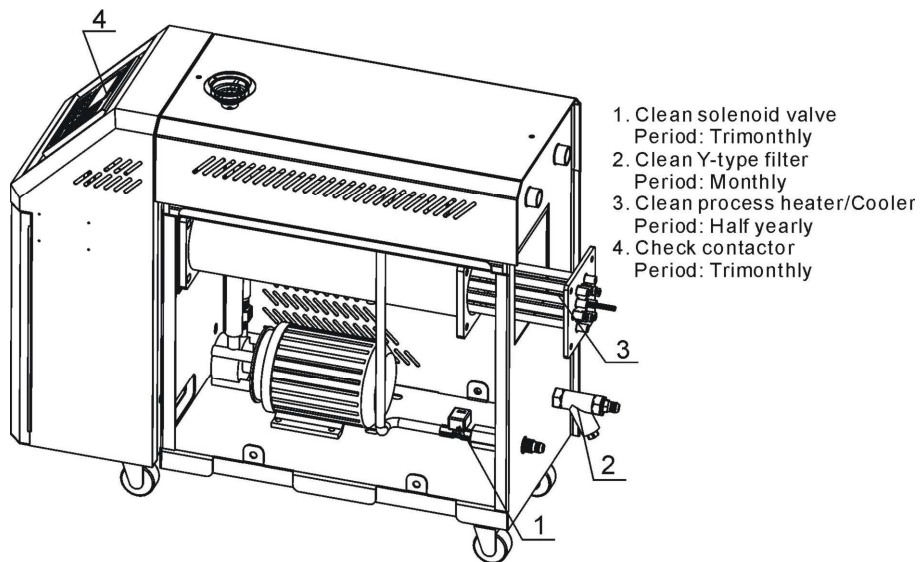

Pay attention to the following rules during maintenance:

- 1) It requires two personnel to check the machine. Firstly, reduce the temperature, cut off the power supply, and drain the oil and water; Make sure to operate after inspection with enough maintenance space.
- 2) When operating, it's dangerous to touch the machine as it is in high temperature state. The operator must stop the machine before checking and maintenance and wear safety gloves before operation.
- 3) In order to extend the life of the system and prevent accidents, periodic inspections must be carried out.
- 4) Please reduce the temperature to room temperature (below 50°C), cut off power supply and drain oil and water first while inspecting the machine; (Please note that it is dangerous to check or tear down the machine during operation.)

6.1 Open the Covers

- 1) Open the top covers of the unit (Lift up it as shown picture).

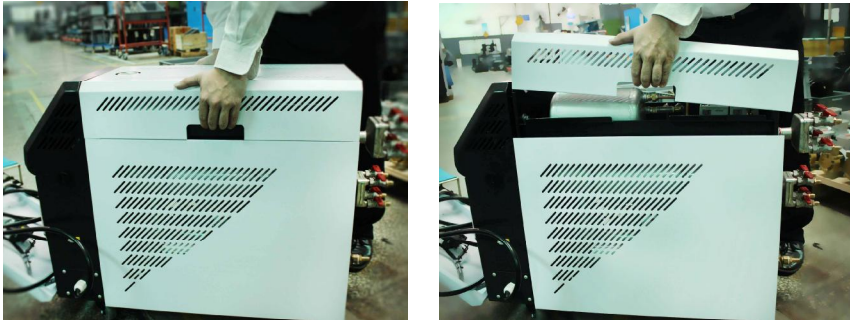

Picture 6-1: Open the Covers 1

- 2) Take down the side covers (Pull up it outward as shown picture).

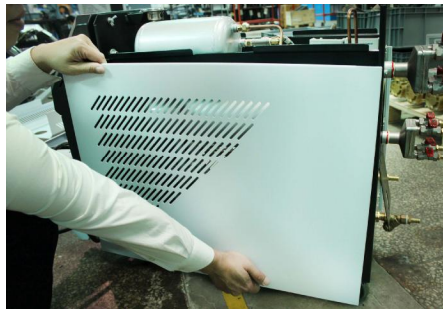

Picture 6-2: Open the Covers 2

- 3) Open the cover of control box. Screw off two butterfly screws to unlock the cover. (Refer to the pictures below)

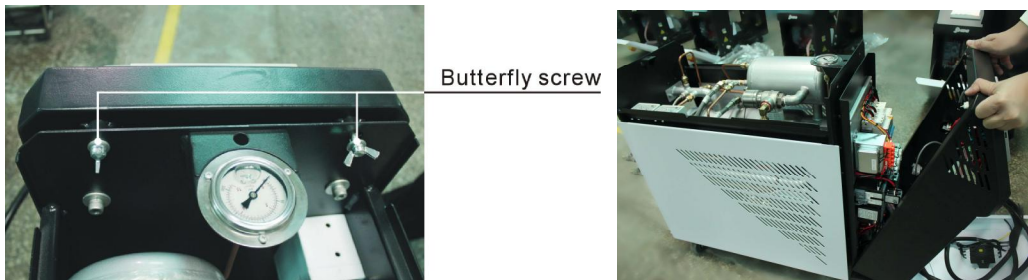

Picture 6-3: Open the Covers 3

6.2 Y Type Strainer

- 1) Clean soft water should be used as cooling water. Filter screen is used in the strainer to stop impurities and pollutants to enter into water pipe.
- 2) Impurities or pollutants may cause errors and bad temperature control. Clean filter screen of the strainer periodically.
- 3) Cleaning steps: turn off power and cooling water supply. Open the top cover of filter screen to clean the filter.



Picture 6-4: Y Type Strainer

6.3 Solenoid Valve

Replace solenoid valve:

- 1) Open machine top cover.
- 2) Take down right side cover.
- 3) Unfix the solenoid valve for replacement.
- 4) Install the covers in a reverse order.

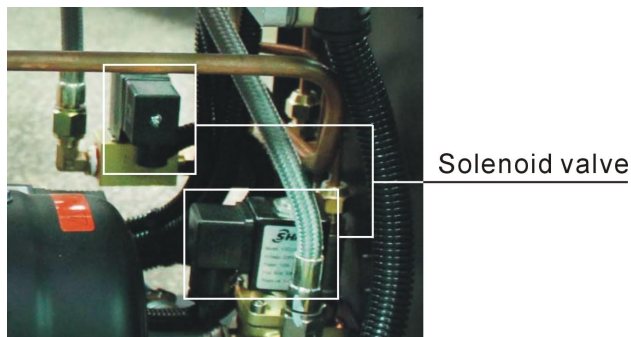

Picture 6-5: Solenoid Valve

6.4 Pipe Heater

- 1) Open machine rear cover door. (Refer to pictures below)



Picture 6-6: Pipe Heater 1

- 2) Unlock heater cap. (Refer to pictures below)



Picture 6-7: Pipe Heater 2

- 3) Unlock the screws of pipe heater to take it out. (Refer to the pictures below.)

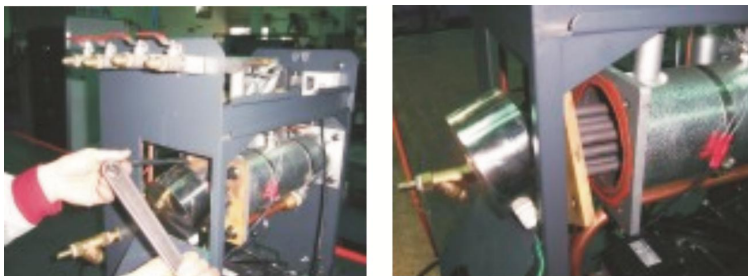

Picture 6-8: Pipe Heater 3

- 4) Install the pipe heater in a reverse order.

6.5 Maintenance Schedule

6.5.1 About the Machine

Model _____ SN _____ Manufacture date _____

Voltage _____ Φ _____ V Frequency _____ Hz Power _____ kW

6.5.2 Installation & Inspection

- Check the installation space is enough as required.
- Check the pipes are correctly connected.

Electrical installation

- Voltage: _____ V _____ Hz
- Fuse melting current: 1 Phase _____ A 3 Phase _____ A
- Check phase sequence of power supply.

6.5.3 Daily Checking

- Check machine startup function.
- Check all the electrical wires.

6.5.4 Weekly Checking

- Check loose electrical connections.
- Check and clean Y type filter ¹.
- Check solenoid valve.
- Check motor overload and phase reversal alarm function.
- Check whether pipeline joints are under looseness.
- Check the sensitivity of EGO.

6.5.5 Trimonthly Checking

- Check level switch.
- Check the contactor ².
- Replace the hot kerosene with a using temperature above 160 degree ³.

6.5.6 Half-yearly Checking

- Check damaged pipes.
- Clean process heater/cooler.
- Check indicator and buzzer.

- Replace the hot kerosene with a using temperature above 120~160 degree ⁴.

6.5.7 Yearly Checking

- Replace the hot kerosene with a using temperature above 120 degree ⁵.

6.5.8 3 year Checking

- PC board renewal.
- No fuse breaker renewal.

- Note:
1. Y-type filter has the function of filling water cooling protection effect, be sure the waterway are clear to avoid cooling failure.
 2. Manufacturer laboratory data for AC contactor is two million times in life. we suggest service life for one million four hundred thousand times, if work eight hours per day, recommended replacing frequency is 1.5 years, if work day and night, replacement is suggested to be done every six months.
 3. Hot kerosene coke will influence the detection accuracy of internal temperature probe and the efficiency of heat elements, three months replacing frequency is suggested.
 4. Hot kerosene coke will influence the detection accuracy of internal temperature probe and the efficiency of heat elements, six months replacing frequency is suggested.
 5. Hot kerosene coke will influence the detection accuracy of internal temperature probe and the efficiency of heat elements, and suggested replacing frequency is one year.